

State of Nebraska

# PAVEMENT MANAGEMENT SYSTEMS

Resurfacing - Reconstruction

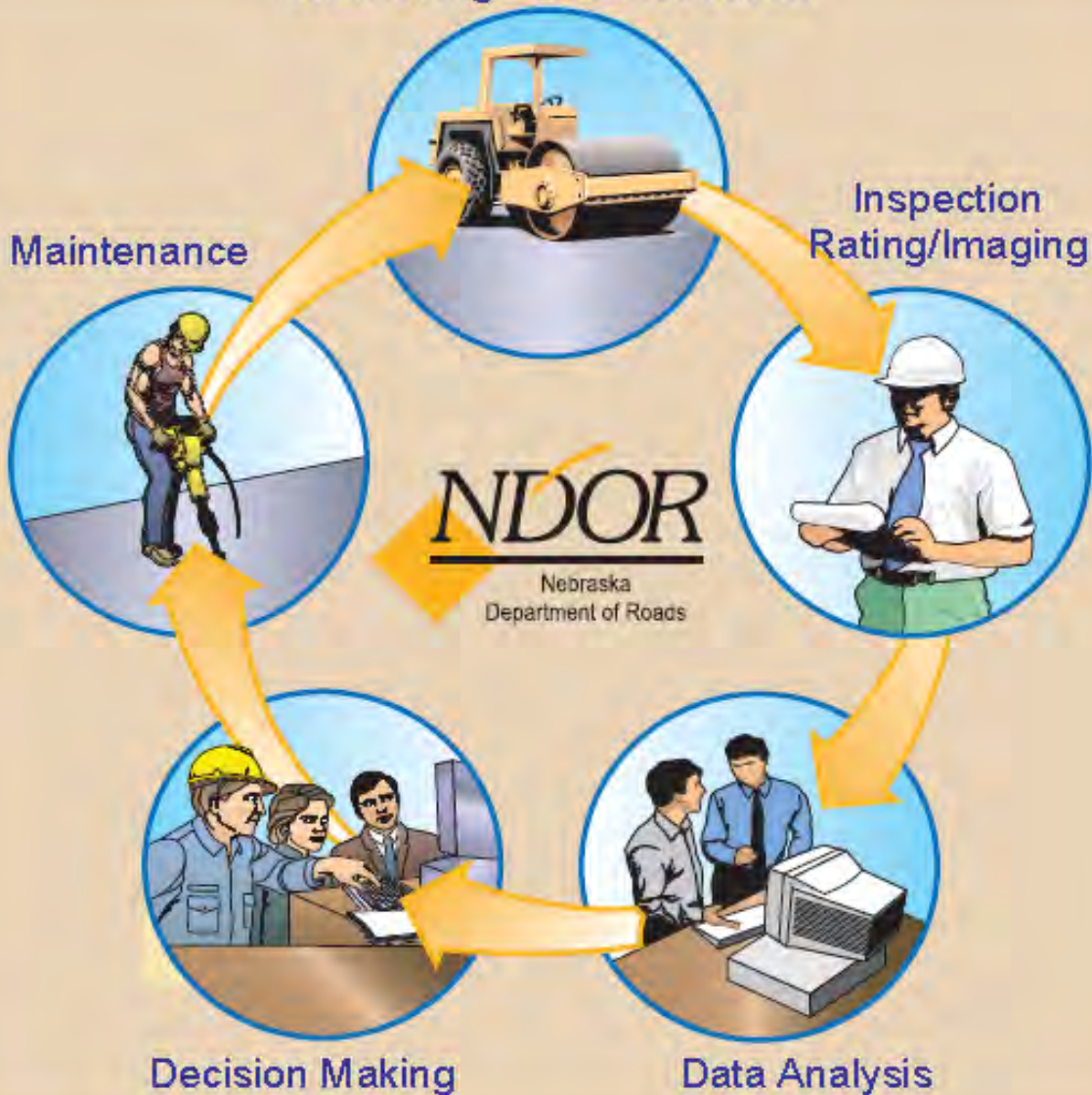

Dave Heineman  
Governor

March 2012

Monty W. Fredrickson  
P.E. Director – State Engineer

## TABLE OF CONTENTS

	Page Number
Executive Summary .....	1
Nebraska PMS.....	2
Revisions and Acknowledgements .....	3
Introduction .....	4
History and Background.....	5-6
Data File.....	7
Analysis of Database .....	8
Bituminous Pavements .....	9
Portland Cement Concrete Pavements.....	9
Present Serviceability Index.....	9
Significance of Distress Measurement.....	9
Maintenance Cost Data.....	10
Remaining Service Life .....	11-16
Selection of Candidate Projects .....	17
Valid Maintenance Strategies .....	17
Pavement Management Data Collection .....	17
Calibration of Profilometer .....	18
Quality Assurance/Quality Control .....	18
Future Work .....	19
Evaluation of Nebraska Pavement System.....	19
Training and Indoctrination.....	19
Statewide Program Analysis .....	19
Replacing Profilers .....	19
Pavement Optimization Program (POP) .....	19
Conclusion .....	20
References.....	21

## LIST OF APPENDICES

Appendix A Decoding PMS Data .....	A-1
Appendix B Pavement Condition Rating.....	B-1
Appendix C Present Serviceability Index Equations .....	C-1
Appendix D Valid Maintenance Strategy Tables.....	D-1
Appendix E Remaining Service Life Equations.....	E-1
Appendix F Faulting Formula.....	F-1
Appendix G Rutting Formula.....	G-1
Appendix H Business Rules.....	H-1

Revised April, 2009

*“The preparation of this report has been financed in part through grant(s) from the Federal Highway Administration and Federal Transit Administration, U.S. Department of Transportation, under the State Planning and Research Program, Section 505 (or Metropolitan Planning Program, Section 104(f)) of Title 23, U.S. Code. The contents of this report do not necessarily reflect the official views or policy of the U.S. Department of Transportation.”*

## **EXECUTIVE SUMMARY**

The Pavement Management System described in the following pages basically fulfills the requirements outlined in the Federal register, Vol. 58, No. 229, Paragraph 500.207. This was accomplished with the 2004 completion of the Pavement Optimization Program (POP) and the Pavement Condition Assessment & Rehabilitation Effectiveness program (PaveCARE). The POP program produces prioritized candidate lists for our preventative maintenance, pavement extension and resurfacing projects that spans up to 20 years using a life cycle cost analysis. PaveCARE performs conditions assessments and evaluates improvement strategies at the network and project level based on performance indicators and tracks the maintenance activities and costs applied to them.

The Network Level Pavement Management System is based on concepts described in the American Association of State Highway and Transportation Officials publications including its 1985 "Guidelines on Pavement Management."

The Nebraska Pavement Management System (NPMS) includes all rural and urban marked and/or maintained highways and recreation roads. As of January 1, 1994 the NPMS also includes all highways and roads on the National Highway System.

The fundamental information used in NPMS includes: 1) pavement inventory data, 2) historical and current pavement condition data, 3) pertinent traffic characteristics information, and 4) construction and maintenance cost information. The general flow of information and development of reports is outlined in the NPMS systems flow chart shown in Figure No. 1.

Collection, computer storage, and reporting of the condition of Nebraska's highways is the responsibility of the Pavement Management Section, Materials and Research Division. Project level analysis is provided by the NPMS.

The following data is included in the NPMS:

1. Length, width, and other layer geometric data.
2. Pavement structure, layer types, and design thickness.
3. Pavement distress condition data for bituminous and concrete pavement, PSI, NSI, rutting, faulting, and roughness (IRI) data.
4. Friction resistance data.
5. Traffic Volume data, equivalent 18 kip axle load information.
6. Construction and maintenance rehabilitations by activity costs.
7. Safety records (fatalities and property damage data).
8. Nebraska Highway Program data for the next six fiscal years.

Nebraska has converted the flat file database programs which have been used in the past to an integrated database system which resides on the Department's mainframe computer. Summaries of major data items can be viewed on line on the mainframe workstations. Printouts and reports of the summarization screens are easily obtained. These databases have also been copied to the P.C. environment where they are available for further analysis. Historical data is being kept for a 50 year time period. Personal computers are used for 1) POP and PaveCARE Programs 2) up and/or down loading data to or from the mainframe, and 3) facilitating computer generated reports. See Appendix H for a description of the DB2 tables.

The analysis procedures for the NPMS are agency specific. The pavement condition data is used to evaluate each segment of highway within the State. Details of the life cycle cost analysis and ranking procedures in POP are outlined in this report.

# NEBRASKA PMS

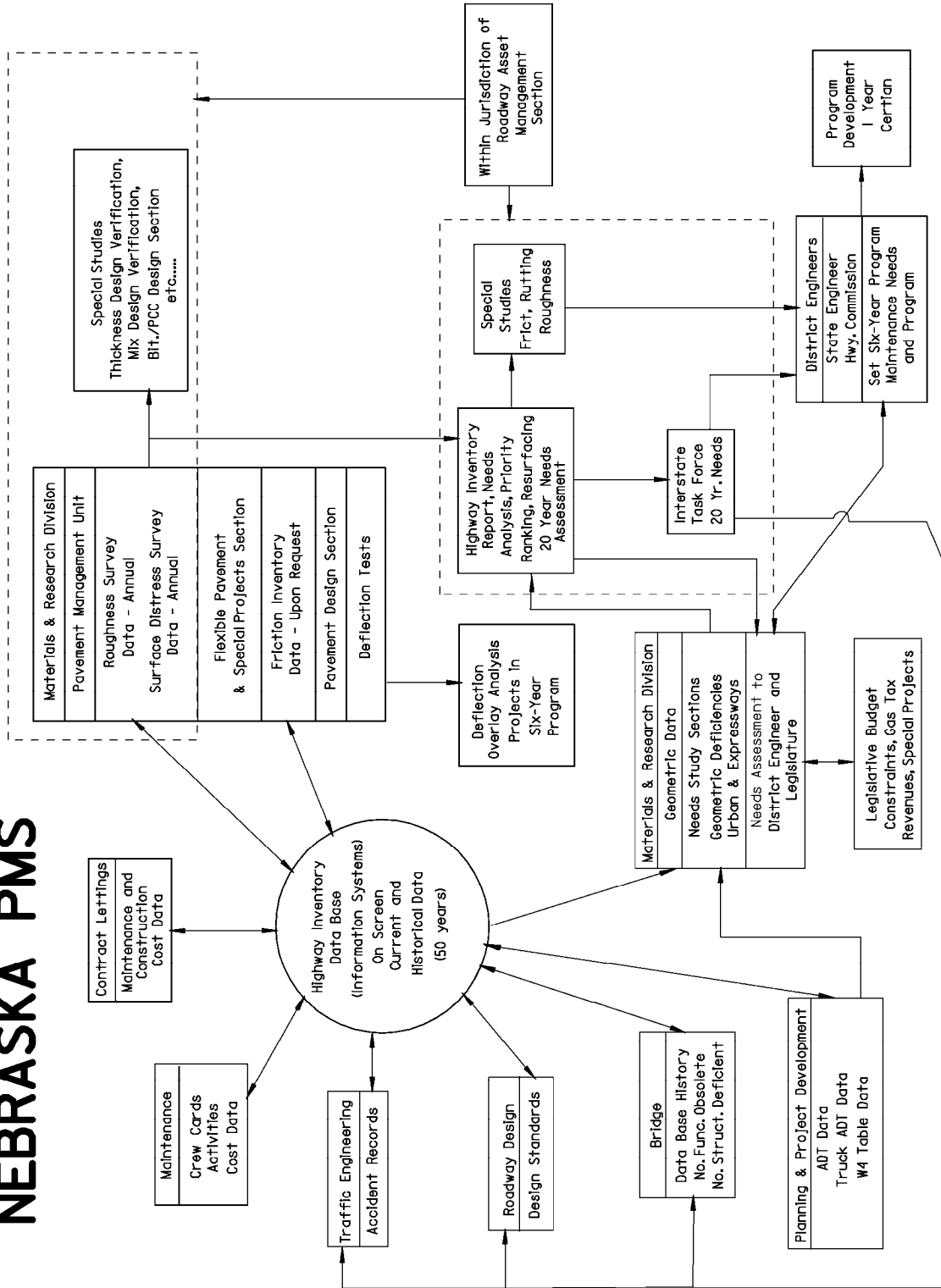

Figure No. 1

A spatial mapping system has been developed to provide additional information for construction and maintenance programming. Maps illustrating current pavement conditions, existing projects and future projects are delivered to the District offices on an annual basis to assist them in their decision making.

In addition to estimating the Department's needs and ranking of candidate projects, the historical condition data and performance measures are reviewed systematically to monitor and evaluate 1) maintenance, rehabilitation, and reconstruction designs and techniques, 2) calibrate performance prediction curves and design procedures, and 3) provide information for special research purposes. Modifications to the NPMS are made when and if statistically significant changes are found to occur. Problems in pavement performance are reported to design engineers for review and study.

The NPMS procedures and modifications have been used by the Department since 1985 for pavement management work. The POP and PaveCARE programs were implemented in 2004 to supplement the current system. These methods have been found to be useful and acceptable for Department work.

The intent of this publication is to provide assistance to highway administrators by describing a range of pavement distresses. It is not intended to be a detailed pavement maintenance manual that could supercede the need for engineering judgment by knowledgeable engineers. The use of verbal descriptions such as "poor" to describe conditions on a segment of road does not imply that the segment of pavement is unsafe, nor does it mandate the initiation of maintenance projects.

## **REVISIONS**

On July 1987 a Pavement Management System manual was distributed to various DOR Divisions and interested agencies, defining various methods and procedures of analysis and interpretation of measured pavement condition data. The manual was revised in 1991 to account for modifications in 1) distress and profile measurement and 2) methods of prioritization of projects for Nebraska's Annual Needs Assessment.

On December 1996 the manual was revised to account for changes in 1) a modification of pavement distress evaluations, with a revision of NSI derivation for bituminous and PCC pavements, and 2) refinements to remaining service life algorithms for pavement evaluation.

On July, 2005 the manual was revised to account for changes in the following: 1) an update to the NSI formula, 2) introduction of the Pavement Optimization Program (POP) and PaveCARE, and 3) documentation of processes and business rules to create databases and reports.

On January 2007, the manual was revised to account for changes in the following: 1) enhancements of the Pavement Optimization Program (POP), 2) a revision of the NSI formula for bituminous pavements, 3) an update to the remaining life formula for PCC pavements, and 4) an introduction to the new Pathway profiling system.

On April 2008, the manual was revised to account for changes in the following: 1) enhancements of the Pavement Optimization Program (POP), 2) a revision of the NSI formula for bituminous pavements, 3) an update to the remaining life formula, 4) incorporate the INO (Pathway) data, and 5) rebuild of the POP database.

On April 2010, the manual was revised to account for changes in the following, 1) Changes in the bituminous and concrete decision trees in POP's life cycle cost analysis. 2) Adjusted the rutting influence in the NSI formula for bituminous pavements.

This report includes (1) Removed age check for NSI on concrete. 2) Minor changes in L.C.C.A. decision trees. 3) Updated costs for improvement strategies. 4) Update to the remaining life formula for bituminous pavements.

## **ACKNOWLEDGEMENTS**

Appreciation is extended to all of the Department Divisions which assisted in the development of the Nebraska Pavement Management System (NPMS). Particular thanks are extended to all the people who devoted a great deal time and effort in building data files and provided comments regarding analysis methods used in the NPMS.

Thanks are extended to the Business Technology Support Division for their efforts in creating the various computer programs for the NPMS system.

The development staff would also like to acknowledge the support provided by upper management in the development of the Pavement Management System. This is absolutely essential if a Pavement Management System is to work.

## **INTRODUCTION**

This report describes the Nebraska Pavement Management System (NPMS) developed by the Department of Roads. It represents an organized approach to providing the Department's Administration with the necessary information to efficiently manage its highways.

The basic components of this system are: 1) a computer master file and 2) interpreting programs. The master file is the foundation of this system. It provides the information for the computer system's Pavement Management Record. The interpreting programs summarize the information and provide reports listing candidate sections of pavement suitable for rehabilitation.

The master file lists all Nebraska highways by highway number and reference post system. The reference post numbers are marked on the highways with mile markers. These are tied to a linear referencing system using logmiles. These logmiles allow you to make a change due to a realignment or expressway routes around urban areas and continue to track the original and new data without having to move the mile markers for the rest of that route. The master file is utilized in several ways: 1) to report existing pavement condition, 2) track progression of distress over the service life of a pavement, 3) list pavement section surface distresses, the extent of the distress, and valid rehabilitation repairs, and 4) report sections programmed for construction.

This master file consists of the several tables that are loaded with visual ratings, automated roughness ratings, programming information and inventory information. Each of these tables store the data differently. For Example: Visual ratings are stored for every mile and material change, Programmed projects information has information for the limits of the project, Automated roughness ratings are collected at 3/4 inch intervals and stored at 0.1 mile intervals. All of this data is tied together with our reference post system and applied to a database that has highway sections determined by beginning and ending reference post limits. We have two different section definitions depending on the need of the database.

There are pavement sections that are predominately homogeneous in design and material type. These sections have combined projects of the same material and similar ages. In some cases very small sections of dissimilar material or age were included in one section. The information is primarily based on the predominant segment of that pavement section. These project length pavement sections are meant to be used at the network level for analysis or for future project planning.

The other type of section is our needs sections (previously sufficiency sections). Needs sections are defined by changes in width, surfaced shoulder, corporate limits, project limits, future traffic etc. in order to identify geometric deficiencies. The needs sections are used in the annual 20-Year Needs Assessment, the State Highway Inventory Report, and the POP program.

Pavement investment decisions require two levels of management. The two levels are: 1) network-level where general administrative decisions are made and 2) the project management level where specific technical elements are evaluated. The POP program generates a list of candidates to assist the District Engineer and other Divisions within the Department in establishing a network-level six-year rehabilitation program. A benefit/cost ratio is used to determine the most efficient way to apply the annual budget.

The Materials and Research Division also uses data from the condition survey to evaluate future project needs and verify present pavement design methodology. Inventory and priority listings for the Nebraska Needs Assessment study report are prepared from evaluation of current pavement condition collected by the pavement management unit.

### **HISTORY AND BACKGROUND**

In 1973 Nebraska initiated a program for measuring the roughness of pavement for present serviceability index (PSI) on all state maintained highways. Dynaflect deflection readings were taken on all bituminous highways except asphaltic concrete resurfacing over Portland cement concrete (PCC). Readings were taken every mile at reference posts. The deflection data provided network-level analysis of soil support condition, thickness design verification, and load carrying capacity of the pavement. The data was used with more detailed information for overlay thickness design for asphaltic concrete over existing bituminous pavement. Data was collected every two years by the Materials and Research Division.

At that time, the Transportation Planning Division was responsible for maintaining a highway sufficiency rating for all state maintained highways. A numerical rating was used. There were two controlling factors used for the Nebraska's sufficiency rating. These were: 1) pavement condition, and 2) safety and service. On concrete and bituminous roads the elements relating to condition were assigned 40 of the total 100 points available and those which affect driving conditions in regards to safety and service 60 points. The condition rating was derived from structural adequacy and roughness data. The structural adequacy was derived from the deflection information using the Dynaflect and the roughness from measurement obtained using a PCA response type road meter. This system provided general information for management regarding programming for the rehabilitation of pavements.

In 1984 the Program Management Division was created to upgrade and implement a more operational Pavement Management System. Some of the objectives of the Division were:

1. Provide a current database for all Divisions concerned with pavements.
2. Annually update the physical condition status of the state highway road network.
3. Provide management with a summary of information from which rehabilitation programming can be implemented.
4. Provide feedback as to the consequences of decisions and ensure consistency of decisions regarding the rehabilitation program.
5. Provide a forecast of future pavement condition.

In 1989, the Program Management Division was dissolved. The pavement management unit was incorporated within the Materials and Research Division. In 1991 the pavement management unit was incorporated into the Logistics Division. Again in 1993 the highway

management unit was transferred from the Logistics Division to Transportation Planning Division. In late 2001 the pavement management unit rejoined the Materials and Research Division.

Success of a Pavement Management System depends on the quality of information available for management. Because of the broad scope of a PMS, it was recognized that considerably more information would be required than had been available in the past. Also, a coordinated effort between all Divisions would be needed.

Initially, a great deal of time and effort was expended in determining what information was essential to the PMS and where it could be found. Fortunately a good portion of the information which was deemed essential was available on computer files. However, a considerable amount of computer programming was required in order to assimilate the important information and provide reports for analysis.

The following factors were considered important for evaluations:

1. Surface condition
2. Present Serviceability Index (PSI)
3. Maintenance activities and costs
4. Geometrics
5. Federal Functional Classification
6. Traffic information
7. Rehabilitation costs
8. Life Cycle Costs
9. Age since initial construction
10. Age since last major rehabilitation
11. Pavement design (thickness and materials)
12. Accident record information
13. Program scheduling and cost data
14. Friction data
15. Deflection data for resurfacing evaluation

The list is not complete but illustrates the complexities involved in highway management practice.

In 1985 a method was developed for measuring surface condition of Nebraska pavements. The method was patterned after procedures developed by Washington DOT(1), Pennsylvania DOT(2), and other agencies interested in pavement condition measurement. The method catalogs the severity and extent of pavement distresses observed on the surface at the time of measurement.

During the winter of 1987 a South Dakota Ultrasonic Profiler was fabricated by the Department for measuring roughness of Nebraska highways. The unit replaced the Mays road meter which was used from 1985 to the end of 1987. The Mays meter was a "response type" roughness measurement device, while the ultrasonic profiler is a digital profile measurement device. The ultrasonic profiler was upgraded to an International Cybernetics Corporation(ICC) laser profiler in 1996. The profiler was fitted with a camera and GPS unit in 2000. The profiler is also used for rut and fault depth measurements. With the addition of the digital camera, images of the pavement surface are collected along with GPS data. Since 1987 the pavement management

unit has included pertinent accident record data in its summary screen. Friction data is now included in the Pavement Management System database.

The Program Management Division and Business Technology Support Division in a joint effort developed a system for summarization of the enormous amount of information available for analysis. The information is structured such that it is readily available to all Divisions via computer terminal. Reports, essentially screen dumps of this information, can be obtained easily while at the terminal. From the database or master file it is also possible to obtain listings of highway segments in need of rehabilitation. Using SAS Institute Inc. programs it is possible to evaluate the list with regard to needs, costs, and other parameters.

In 2004, version 2.1 of the Pavement Optimization Program (POP) was distributed to the District offices. This program allows you to investigate your current pavement ratings, look at the associated photographs and link to our Mandli Roadview Explorer. It also has a life cycle cost analysis which prompts you to enter an analysis period and annual budgets. A yearly output report shows those selected sections that would be improved based on the budget and the benefit cost ratio. There is also a graph of the NSI after each year's improvements. That same year PaveCARE was implemented to perform condition assessments and evaluate improvement strategies at the network and project level.

In 2007, Version 2.5 of POP was released with additional functions including a mapping feature and a direct link to the 2006 roadway photos. These photos were collected with the newly implemented Pathways Profiling Systems. In 2008, we released version 2.8. This added a link to the log book, created a cross-section diagram, adjustments to the life cycle cost analysis and data grid.

In 2008, version 2.9 was also released. The major change was to replace the "Reconstruction" strategy in the life cycle cost analysis decision trees with "Resurfacing" for bituminous and "Rehabilitation" for concrete pavements.

The Nebraska Department of Roads intends to keep abreast of current concepts of pavement management and implement methods of data collection and analysis which will provide processes for improving the system.

## **DATA FILE**

The computer files used for the pavement management system are:

1. Integrated Highway Inventory (IHI) file
2. Maintenance Activity and Cost file
3. Design History file
4. Surface Condition file
5. Pathway's Profiler, and rut and fault depth measurement files
6. Programmed Construction file
7. Dynaflect and Falling Weight Deflectometer files
8. Accident Record files
9. Bridge condition files
10. Friction data files

The Materials and Research Division maintains the deflection data, friction data and the thickness design information and their pavement management section is responsible for the surface condition and profiler information. The IHI file is the responsibility of the Business Technology Support Division. Maintenance activity and cost is managed by the Controller

Division. Programmed construction data is maintained by the Project Scheduling & Program Management Division. Accident records are maintained by the Traffic Division and the Bridge condition is maintained by the Bridge Division These files are continuously updated throughout the year by each responsible Division.

A manual for decoding pavement management condition data is included as Appendix A of this report. This appendix contains a listing and definition of data items selected for review. Specific data elements will be discussed in the following sections. Items not discussed will be presented in the appendices.

The surface condition file is a complex system providing coded surface distress information for the State marked or maintained highways, spurs and connecting links. Also data for the National Highway System and recreation roads are included. Items contained in this file consist of type, severity, and extent of surface distress. Also included is data for shoulder condition.

The roughness data from 1985 to 1987 was collected with the Mays Roadmeter. From 1987 to 1996 the roughness of pavements has been measured with the South Dakota profiler. From 1996 to 2006 the pavement roughness, rut depth and faulting has been collected with the ICC profiler. Then in 2006, a Pathway's profiling system was implemented to collect pavement roughness, rut depth, texture and faulting as well as photos. Roughness data is in terms of the International Roughness Index (IRI). The average IRI, rutting and faulting for each 0.1 mile of the State highway system is incorporated into the database.

This Pathway profiling system collects roughness and rutting data with a three-point laser for the left, right and between wheel paths. It also has a laser measurement system which has a transverse profiling device (referred to as our INO system) that digitizes a transverse section. The advantage to this system is that it can take into account for vehicle wander. The average rutting we use is the average from the left and right wheel paths from the INO system if they are within 6 mm of each other, if not, we use the lower of the two wheel paths.

When new projects are programmed, their limits are defined and recorded on file. This file also includes the type of improvement planned, its cost, and the expected year of implementation.

The information contained within the files is basically raw unprocessed data. For certain items such as Nebraska Serviceability Index (NSI) or Present Serviceability Index(PSI) for example, the raw data is combined to provide a numerical index. This type of data is calculated and displayed on the terminal screen or printed report.

## **ANALYSIS OF DATABASE**

The interpreting program performs several basic functions. The program converts the raw distress data into numerical ratings, produces a performance curve for each section, plots the past ratings, computes average surface maintenance costs, etc.

For Nebraska pavement management analysis, the surface condition data is combined using type, severity and extent of surface distress and the rutting or faulting measurement to provide a single value termed the Nebraska Serviceability Index (NSI). This provides a single value which can be used to monitor pavement performance with time. The NSI rating is calculated using a combination of the visual distresses and the rutting or faulting.

The NSI identifies projects with multiple distress problems since it also includes the rutting or faulting information. Evaluation of individual distress severity and extent provides a further means for evaluation of pavement. The algorithm for derivation of the NSI is given in Appendix B of this report.

The severity and extent of the individual distresses observed at a sample site are numerically defined. After the data is input to computer file, the distresses are combined mathematically into pavement condition factors. Each factor includes distress forms which tend to be similar to each other.

### Bituminous Pavements

The NSI for bituminous pavements represents the condition of the pavement at the time of survey. The value of the NSI does not necessarily reflect the rate of pavement deterioration. For evaluation of remaining service life of a pavement, the current and historically low NSI for the pavement are evaluated along with the general rate of pavement deterioration as observed over time. The final remaining service life is based on evaluation of all distress factors. The lowest remaining service life value of the pavement is used for further analysis.

The procedure for derivation of the NSI is reviewed systematically and updated if needed. In 2006, a check was added on the rutting measurement to increase the effect it has on the NSI. If the average rutting is greater than 8 mm, then the NSI is set to a maximum of 60. This will affect the remaining life formula and make that section past optimum and past critical years.

In 2007, another check was added based on age. If the age > 10 then the maximum NSI = 88. If the age is between 6 and 10, the maximum NSI = 92.

In 2008, we changed the rutting check. If the rutting is greater or equal to 9 mm then the maximum NSI is 60. If the rutting is greater or equal to 8 mm and less than 9 mm then the maximum NSI is 71. And, if the rutting is greater or equal to 7 mm and less than 8 mm the maximum NSI is 82.

### Portland Cement Concrete Pavements

Rigid pavements, because of their forms of distress, are rated differently than bituminous pavements.

$$\text{NSI} = 100 * \text{FACTOR}$$

Where FACTOR = f(Joint repair & condition, Panel repair & condition, Pattern cracking, and Faulting)

The severity of joint and panel spalling, cracking, faulting, pattern/ASR(alkali silica reaction) cracking are evaluated. If the pavement has been repaired, the number and condition of the repairs is evaluated. Faulting of the pavement, at transverse joints and cracks, is measured to the nearest 1/100<sup>th</sup> millimeter by the Nebraska Pathway's profiler. Faulting on longitudinal cracking is evaluated and rated at each sample site.

Details of deriving NSI for PCC are given in Appendix B. The NSI is a combination of the impact of several forms of pavement distress.

In 2008, a check on concrete was added based on age. If the age is greater than 10 mm then the maximum NSI is 88. If the age is between 6 mm and 10 mm then the maximum NSI is 92.

In 2010, the check on concrete based on age was removed.

### Present Serviceability Index

The International Roughness Index (IRI) is used with other distress elements for deriving the Present Serviceability Index(PSI). The PSI was developed at the AASHTO Road Test for estimating how well a roadway is serving the traveling public. The PSI is on a scale of 0 to 5

with 0 being the worst and 5 the best. A key for decoding roughness data is shown in Appendix A. The equations used to derive PSI from IRI are given in Appendix C.

Significance of Distress Measure

The NSI and PSI provides a numerical value which can be used for evaluation of current pavement quality. As a guide to interpreting the NSI and PSI, the following subjective descriptions apply:

<u>NSI</u>	<u>PSI</u>	<u>Verbal Descriptions</u>
90 thru 100	4.0 thru 5.0	Excellent (Pavement like new)
70 to 90	3.0 to 4.0	Good (Several years of service life remaining)
50 to 70	2.0 to 3.0	Fair (Few years of service life remaining)
30 to 50	1.0 to 2.0	Poor (Candidate for rehabilitation)
0 to 30	0.0 to 1.0	Very Poor (Possible replacement)

Maintenance Cost Data

This data is important to any valid analysis of pavement condition. High maintenance costs often are associated with short term increases of PSI and NSI. The tabulation which follows lists the activities covered:

<u>Activity Code Number</u>	<u>Activity</u>
2002	Road Profiling
2003	Minor Milling
2004	Armor Coat Rdwy Surface
2005	Fog Seal
2007	Mudjacking
2009	Municipal Maint. Agreement
2010	Joint and Crack Filling
2013	Joint Cutting
2015	Subgrade Repair
2025	Machine Patch Rdwy Surface
2026	Spot Patching
2027	Concrete Patching
2030	Surf. Shoulder Maintenance
2031	Grading of Shoulder
2032	Rebuilding Unpaved Shoulder
2035	Blading Unpaved Road
2036	Major Restoration Unpaved Roads

An important aspect of pavement work is the concept of excessive maintenance costs. It is possible to extend the life of a severely distressed pavement by providing extensive heavy maintenance. Thus, a pavement might be considered to have reached the end of its design life when it reaches a poor level of serviceability, distress, or when cost of maintenance becomes too high.

Statistical evaluations against engineering judgments have provided the following scale:

<u>Average Five-Year Maintenance Cost</u>	<u>Description</u>
<u>Lane Mile Cost</u>	
Under \$250	Good
\$250 to \$700	Fair

Over \$700

Poor

The maintenance cost reflects only work performed by the Department for surface and shoulder work only. Contract maintenance costs which include armor coat, fog seal, slurry seal, or machine patch work are not included in the current maintenance cost file. Cost data for these contract projects are reported with the Nebraska highway program report published each year.

Surface maintenance data for rural pavements is of value in the analysis and evaluation of the performance of these pavements. In several large urban areas, the responsibility of the surface maintenance of Nebraska highway segments is theirs. In these instances, a fixed amount of funding is provided for the upkeep of these roads. For these cases, the actual maintenance data is not available

In 2002, NDOR started the Preventative Maintenance (PM) Program through contracts. These PM contract costs have been combined with department maintenance costs to give us a total maintenance cost for a section. This information is displayed in a new software called PaveCare, which was developed in a joint effort with the University of Nebraska and the Materials & Research Division. This program allows you to summarize distresses for bituminous or Portland Cement concrete and track the performance of improvement strategies including maintenance costs. The performance trend lines of the strategies determined by PaveCare can be used as deterioration rates and benefits in our POP application.

Except for the special urban sections, State maintenance cost data is available for each mile of highway within the state. A record is kept of the last five years of maintenance activity. For analysis purposes, this data is averaged and reported on the pavement management report, computer terminal screen, the POP program and the PaveCare program.

#### Remaining Service Life

Candidate sections for rehabilitation can be selected from existing ratings and distress condition items. Another major function of pavement management is to also predict when a pavement will reach a condition needing major rehabilitation.

The condition factors used for calculating the NSI can be used to evaluate service life of a pavement. The NPMS uses a family of linear regression models to derive remaining service life (RSL) of a pavement segment. There are remaining life family curves for bituminous, composite (asphalt over PCC) pavement, and PCC. The equation selected for RSL analysis depends upon 1) primary pavement distress factors, 2) pavement functional classification, 3) pavement type, 4) Current NSI value. The number of regression curves for bituminous pavements has been expanded to account for changes in overlay design policy by the Department. In the past, all resurfacing designs have been based on a 20 year design period. Due to the increasing backlog of candidates for resurfacing projects and limited budgets, this policy has been changed to allow for variable design service lives. This has been termed the "pavement service life extension program" or PEP. Deterioration rates for these pavements were developed from data for pavements designed for periods less than 20 years. These values will be updated with time as more PEP data becomes available for analysis.

The base mathematical model used to calculate RSL is:

$$RSL = (Current\ NSI - Threshold\ NSI) / SLOPE$$

Where: RSL = Remaining Service Life

SLOPE = Deterioration rate, a function of pavement type

Remaining service life is defined as the projected time it will take for a pavement to deteriorate from its current condition to a threshold value. The RSL is used to calculate the optimum year for resurfacing a pavement with a conventional overlay.

After the threshold value has been surpassed, the remaining service life is set to zero. Development of the RSL equations beyond this point is moot. See Figure No 2 for remaining life flowcharts for bituminous and pcc pavements.

When major rehabilitation is accomplished, such as resurfacing, the age of the pavement is reset to zero and the typical pavement rates of deterioration are used. Efforts were made to derive various slope values for differing minor maintenance activities such as spot patching, machine patching, spot surface treatments, and so forth. No statistically significant differences in pavement rate of deterioration could be detected. Sensitivity of condition measurement and time interval between condition measurements prevented proper development of these deterioration values.

Appendix E provides a list of the SLOPE values used for RSL analysis. The deterioration rates, SLOPE, are determined from analysis of historical pavement condition data. These rates of pavement deterioration are evaluated systematically and adjustments to the equations are made when necessary.

In 2006, we made an adjustment to the remaining service life formula for PCC. We wanted more influence for joint condition and pattern cracking. This will help us track the Alkali Silica Reaction (ASR) more efficiently. See Appendix E for details.

In 2007, we made another adjustment to the remaining service life formula. If the PSI controls and the optimum year is "PSTO", then the maximum NSI = 70.

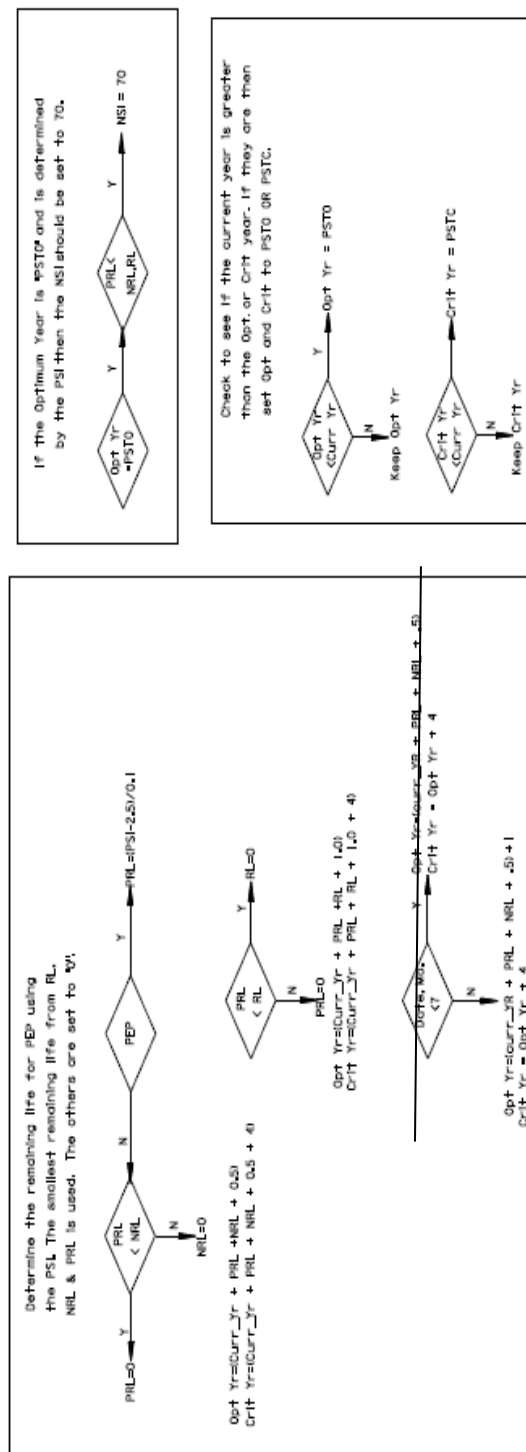
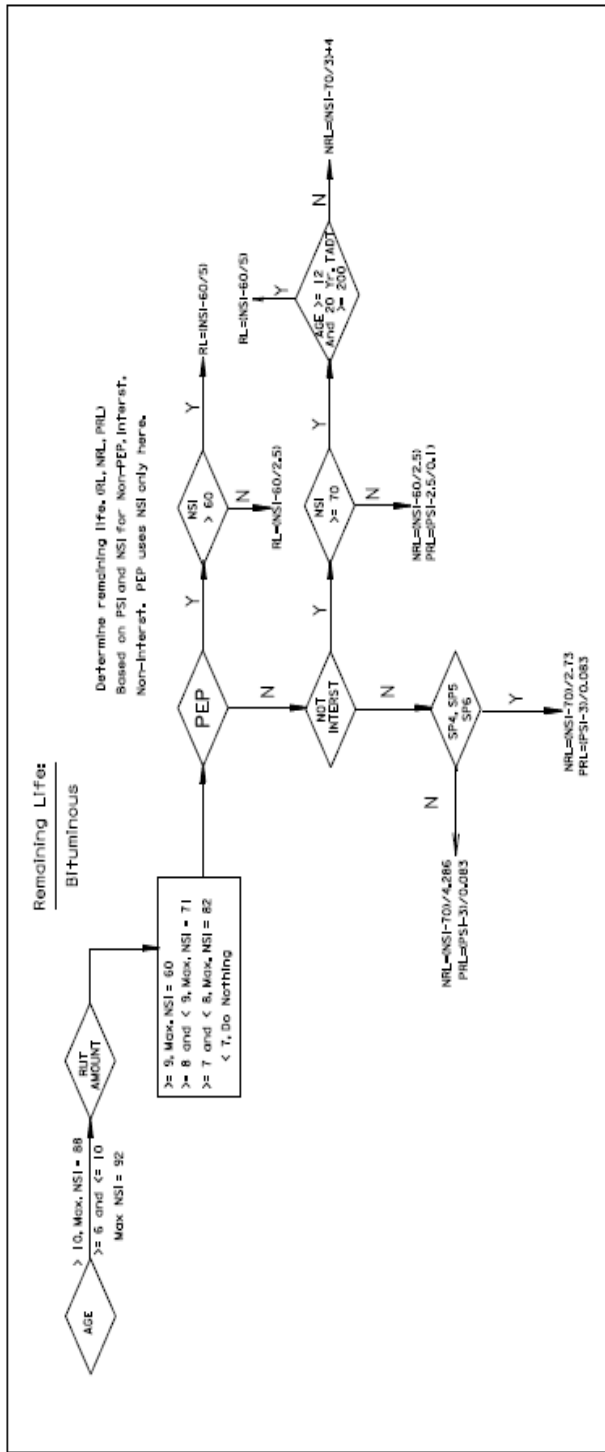

Figure No.2

Remaining Life:  
Bituminous-Continued

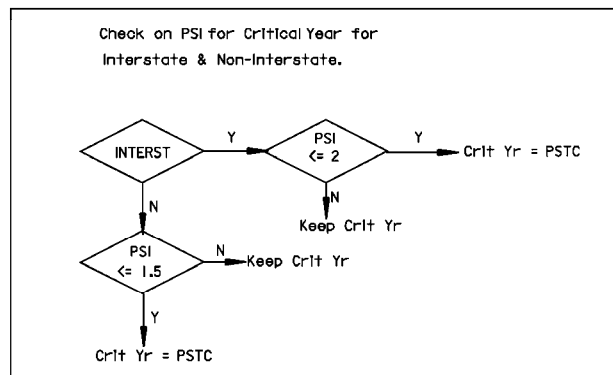
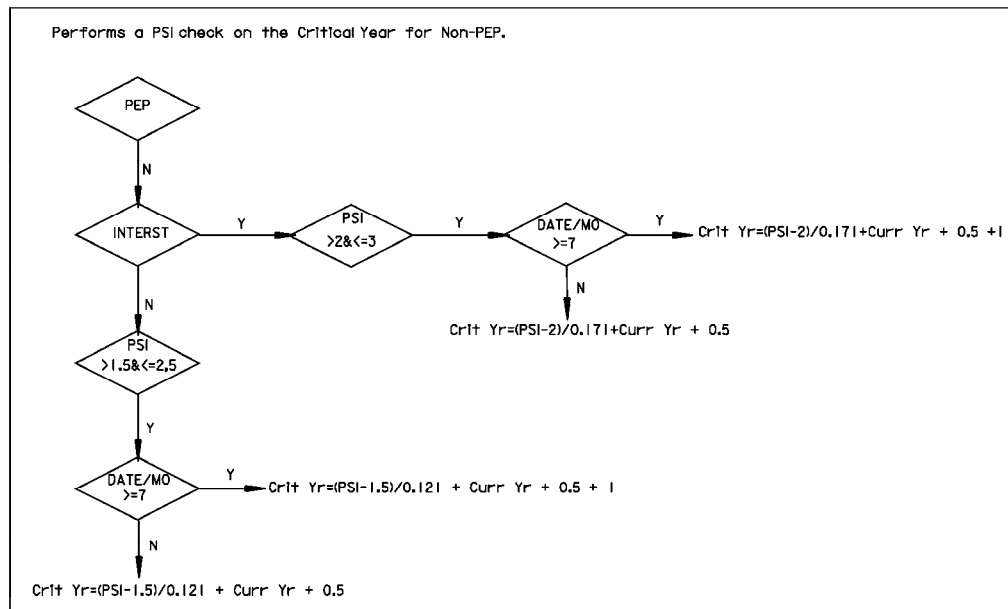
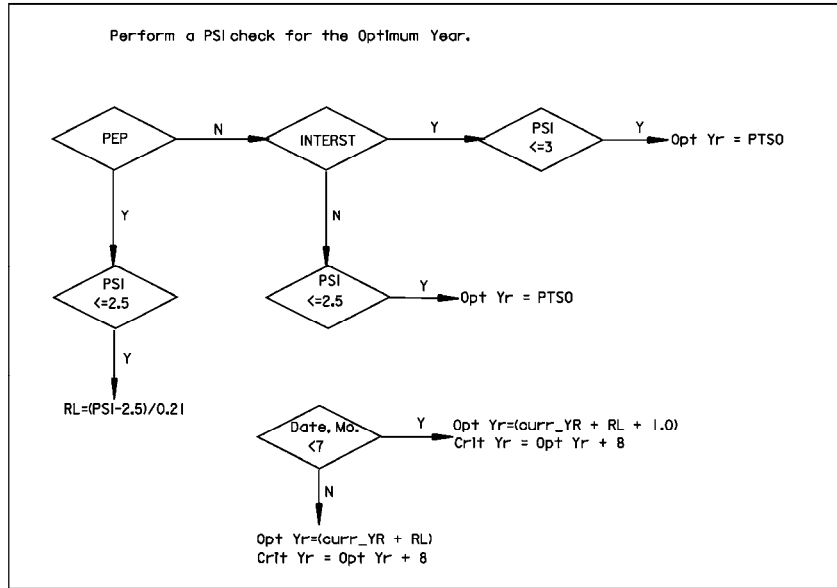

Figure No 2: Remaining Life: PCC

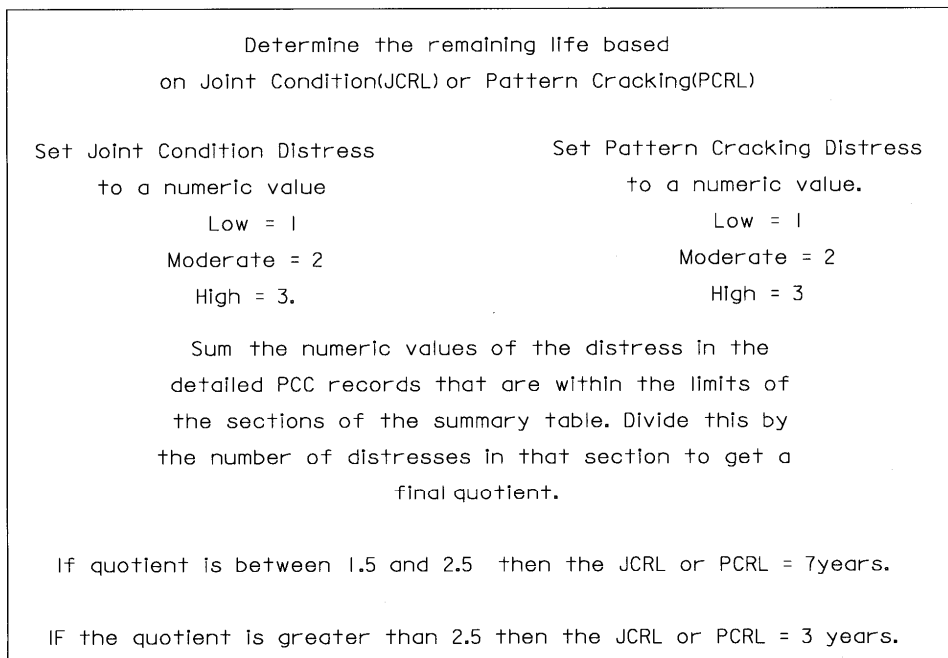
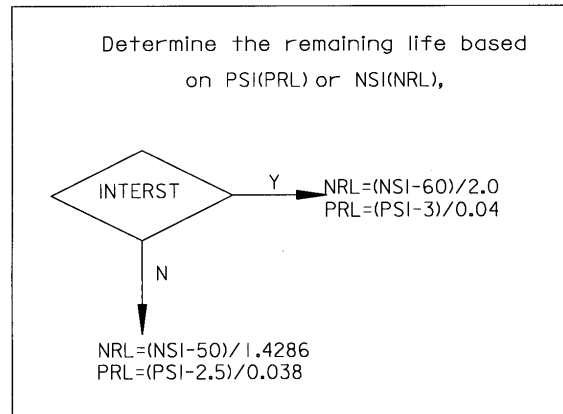
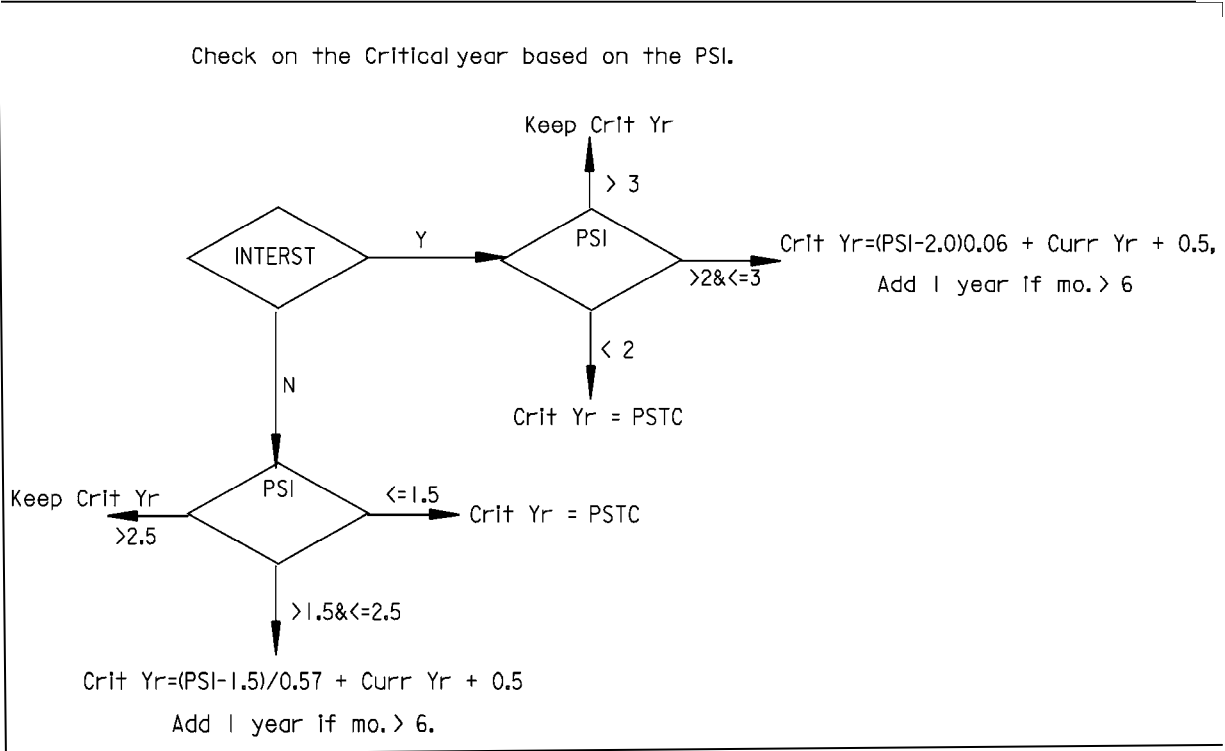
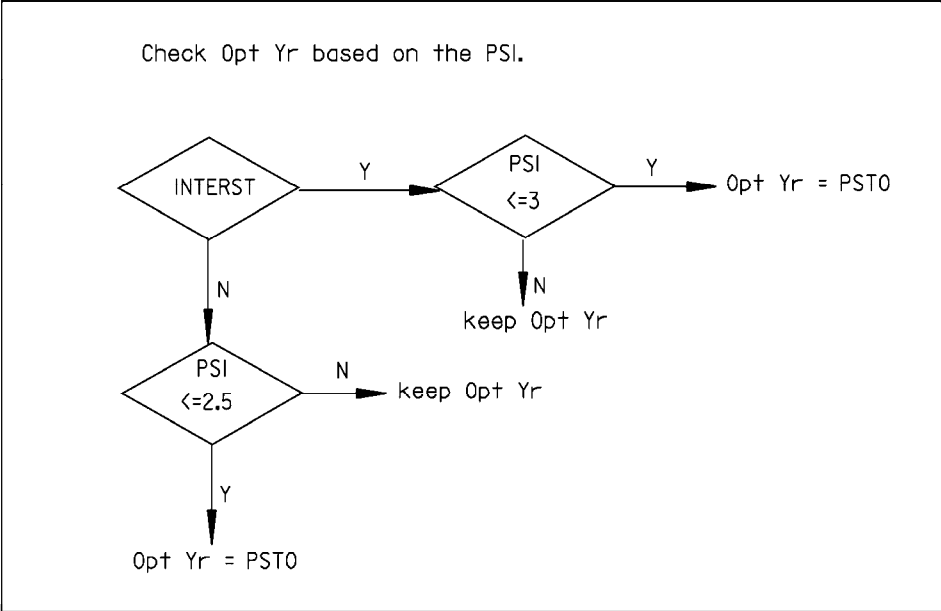

Figure No 2: Remaining Life: PCC (continued)

Set the highest 3 of PRL, NRL, JCRL and PCRL to zero.  
 $Opt\ Yr = (Curr\ Yr + NRL + PRL + JCRL + PCRL + 0.5)$  (ADD 1 YR IF MO. > 6)  
 $Crit\ Yr = Opt\ Yr + 6.25$   
 If Opt Yr or Crit Yr < Curr Yr then set them to PST0 or PSTC.



## **SELECTION OF CANDIDATE PROJECTS FOR CONSTRUCTION PROGRAM**

Based on legislative directive, the Department is required to annually assess the needs of the state highway system. In the assessment process, the highway system is grouped by Interstate, Expressway, Urban, Other Rural, and Gravel. Each group consists of highway segments of specific characteristics of appropriate size for construction contracts. The functional characteristic of each group dictates the method used in ranking the segments for consideration for construction, reconstruction, resurfacing or rehabilitation projects. The "Needs Assessment" provides an investment analysis that includes a network-level analysis that estimates total costs for the present and projected conditions across the State highway system.

The Pavement Management/Classification & Needs Section is also responsible for publication of the Interstate program report, the prioritization report of the other rural highway segments, and the inventory report of the Nebraska highway system. This information is given to the district engineers and their highway commissioners to use for assisting in establishing future construction programs. All reports reflect the basic intent of pavement management to provide the decision makers with sound information to assist them in their decision making process.

A project level analysis is performed by the POP program to produce a list of candidates that have the best benefit/cost ratio for improvement with a limited budget. The POP program will deteriorate the pavement sections for up to a 20 year period and select the most efficient strategies based on the best benefit/cost ratios for each year for the annual budgets applied. This supplements the current decision making processes that exists at the project level.

Historically there have always been more candidates for major reconstruction or rehabilitation than can be included in the highway construction program. These projects may be excluded for various reasons but kept in service with extensive major maintenance. The current pavement management policy is to keep a historical record of projects deteriorating to condition warranting their inclusion as candidates for major rehabilitation. If these projects are not included in the six year construction program, they are carried forward to the next year of analysis. These projects then compete with those which have deteriorated to the extent to justify their inclusion in the program. Those projects carried forward will be ranked again on the basis of their existing condition.

## **VALID MAINTENANCE STRATEGIES FOR NPMS**

The Nebraska Pavement Management System (NPMS) relates pavement conditions to maintenance as well as rehabilitation strategies to extend pavement life and increase level of service. Strategies are either preventative or corrective. See Appendix "D"-Pavement Distress & Related Valid Maintenance Strategies. The strategies are assigned to keep pavements at a reasonable condition to serve the traveling public. The system was developed using the Pennsylvania DOT STAMPP system as a model(2).

## **PAVEMENT MANAGEMENT DATA COLLECTION**

The pavement condition surveys are performed by trained pavement raters. There are five pavement raters in the Materials and Research Division under the Pavement Management/Classification & Needs Section. Three are full time and two are part time raters.

All bituminous and PCC pavement condition ratings are collected annually. The condition data is used for calculation of the NSI and PSI. Starting in 2006, District 5 and large urban area ratings were performed by using the photos collected with the new Pathway's profilers and viewed with the Pathview browser. Our intent is to rate a different district each year from the photos.

Roughness surveys are also conducted by the Pavement Management Section of the Materials and Research Division. The State maintained highways, spurs, connecting links, recreation roads, excluding gravel or earth roads, are surveyed each year. This also includes roads on the principal arterial urban routes.

### **CALIBRATION OF PROFILOMETER**

Periodic calibration of the profilometers laser sensors, accelerometers and distance measuring instrument is necessary to ensure accurate and repeatable results. Laser sensor height calibration is automatically calculated by the mobile data collection software and sensor correction factors are derived from the three sensor system when the laser height is measured off of a level reference plane. Dual accelerometers are automatically calibrated using the self calibration function within the data collection software. Distance measurement factors are calculated as needed over a predetermined distance. Nebraska's two profilometer units are evaluated monthly during the collection season. Both units are driven over various one mile test sections. Test sections represented are of different surface types, roughness, and rutting values. Repeatability of the data from each unit is monitored and both units are compared against each other. Continuous system checks by the computer system ensures that all components are operational during the collection mode. See Appendix F (Faulting Formula).

Friction measurement data was collected at half mile intervals on State maintained highways, spurs, and connecting links. Roads on the NHS were also included. The Friction inventory information was collected over a three year period with a skid resistance tester. In 2006 the scheduling for friction tests with this equipment was changed to be performed on a project basis upon request. All surface texture information will now be collected with the new Pathway's profiling system. This surface texture data is collected at every 3/4<sup>th</sup> inch interval and averaged at 1/10<sup>th</sup> mile points for the entire system. The data is stored on the highway inventory database and archived over a 50 year period. The Materials and Research Division is responsible for collection of the friction data.

Deflection data which includes Falling Weight Deflectometer (FWD) information is measured on pavements as requested by the Pavement Design Section. The deflection information is used for structural capacity analysis, evaluation of existing subgrade strength, and overlay analysis. Deflection test locations and frequency will vary according to project conditions. Data is collected by staff of the Materials and Research Division.

Other data is be maintained by the appropriate agency. The pertinent information for the NPMS is updated periodically by the Business Technology Support Division.

### **QUALITY ASSURANCE/QUALITY CONTROL**

The restoration index (RI), is based on type, extent and severity of each distress that is observed on each bituminous pavement section. This concept is one that has been developed over a period of time based on studies done by many different highway agencies. Any major change (> 10%) from the previous years RI is verified as part of our quality assurance.

Restoration index of a bituminous pavement is calculated from the following general equation:

$$RI = 100 * \text{FACTOR}$$

$$\text{FACTOR} = f(\text{Severity and extent of surface distresses})$$

In addition to this, approximately 10% of the system is spot checked in the field. In the office we check for duplicates and gaps in the data and correct them. Also, the one year old projects are checked to make sure we are using visual ratings and profiling data from the new construction.

## **FUTURE WORK**

### **Evaluation of Nebraska Pavement System**

The information, mathematical models, and algorithms used for the Nebraska Pavement Management System will be reviewed systematically. The system will be updated to reflect the Department's current engineering criteria and practices when necessary. Any updates or revisions will be documented at that time.

### **Training and Indoctrination**

An important aspect for a successful NPMS is the training and indoctrination. This consists of instruction about data collection and uses of a Pavement Management System in maintenance, design, and program development.

The pavement condition rating system will be reviewed annually with the pavement condition raters to insure consistency in the rating process. This includes identification, classification of severity, and determination of extent of distresses observed on Nebraska pavements.

### **Statewide Program Analysis**

Currently the "Needs Assessment" resurfacing reports are developed annually using the SAS software system and the pavement management database. The POP program performs a project level analysis which produces prioritized lists of candidates for improvement strategies with budget constraints for each District spanning up to 20 years.

### **Replacing Profilers**

In 2006, Nebraska replaced their two profiling vans. This new technology will give us improved photos with more views available. This will enable us to observe and rate more pavements from the office. We will also get an improved transverse profile for determining rutting depths. Along with the improved data will be a dual monitor workstation with software for analysis and reporting capabilities.

### **Pavement Optimization Program (POP)**

Future work on the program should include capabilities for the user to include the current programmed pavements in the life cycle cost analysis with options to override them. We would also like to be able to configure and save the data table layout for individual users. We have added the option of loading either Pavement or Needs sections, created an option to display the sections on a map, linked to the log book, added a cross-section diagram, updated the life cycle cost analysis, and changed the data grid.

We are planning to move our POP program and the Pathview Browser to a web application on the internet by the Fall of 2010.

## **CONCLUSION**

Pavement management practice is not a totally new concept. The Nebraska Department of Roads has utilized many of the basic components of PMS for several years. Sound pavement management requires evaluation of a large number of factors, evaluation of the interaction of these factors, and development of a highway program based on appropriate analysis. Comprehensive pavement evaluation requires the consideration of so many factors that it is still a task best performed by individuals in the pavement field with considerable knowledge about pavement. However, it is impossible for any individual to maintain in his/her memory knowledge about the current condition of all maintained highways and projected trend of performance in order to provide an optimum program of highway development which maximizes benefits while minimizing costs with various external fiscal restraints.

The computerized NPMS data provides in capsule form a knowledge base for evaluation of individual segments of the Nebraska highway system. This is much like having a telephone directory of all names, addresses, and phone numbers of all people within a city. The NPMS is this type of directory but it also includes the state of health of the individual highway segments. Programs have been developed to analyze the entire system and indicate which segments are candidates for rehabilitation. Lists can be provided which categorize projects not now programmed but good candidates for major rehabilitation or reconstruction in the future. These lists have been developed on the basis of current so called "state-of-the-art" pavement management techniques as well as incorporation of policy, knowledge, and reasoning used in the past for selection of projects for the six year program. The NPMS provides an advantage over individual evaluation and assessment in that no stone is unturned. All pavement segments are evaluated and none forgotten. This system has been supplemented by the POP program which gives you the life cycle cost analysis and benefit cost ratios. Reports can be run that give you candidates for improvement strategies for the next 20 years. Preventative Maintenance reports are also provided which indicate appropriate network level maintenance strategies for these pavement sections. The Nebraska Pavement Management System's generated reports and maps provide the engineer with a catalog of projects which meet or exceed various threshold conditions deemed important for reliable pavement performance analysis.

A problem does exist in that current pavement condition indicates that there are more roads in rehabilitation needs than there are funds available for their reconstruction or resurfacing. This will require postponing major rehabilitation on certain projects until sufficient funds are available. In the interim these pavements will require major maintenance in order to maintain a satisfactory level of service to the traveling public. Reports are provided which indicate appropriate network level maintenance strategies for these pavement sections.

Closer adherence to this type of ranking or prioritization provides a greater economical benefit to the taxpayers. An important step in the use of the NPMS is the education of its users. Certain Department personnel should be adequately trained in how the data is collected and maintained, as well as in the uses of the Pavement Management System.

## REFERENCES

- 1) Nelson, T. L. and LeClerc, R. V., "Development and Implementation of Washington State's Pavement Management System," Washington State Department of Transportation, Olympia, WA, (September 1982).
- 2) "Systematic Technique to Analyze and Manage Pennsylvania Pavements," Special Task Force on Pavement Management, PENNDOT, (October 1983).
- 3) Hair, J. F., Anderson, R. E. and Tatham, R. L., "Multivariate Data Analysis," Second Edition, Macmillan Publishing Company, New York, Collier Macmillan Publishers, London, (1984).
- 4) SAS System Software, Release 6.03, SAS Institute, Cary, NC, (1988).
- 5) Baladi, G. Y., Novak, E. C., Jr. and Kuo, W., "Pavement Condition Index-Remaining Service Life, Pavement Management Implementation, Holt/Gramling, editors, ASTM STP 1121, (April 1992).
- 6) HRB Special Report 61E, "The AASHO Road Test Report 5," Pavement Research, (1962).
- 7) Hudson, W. R. and Pedigo, R. D., "Simplified Pavement Management at the Network Level," TRR No. 846, Washington D. C., (1982).

# **APPENDIX A**

## **MANUAL FOR DECODING PAVEMENT MANAGEMENT CONDITION DATA**

## Introduction

The pavement management records of pavement condition are viewed on the Departments' C1 mainframe system. The system consists of several screens of information for each highway segment. This Appendix lists a glossary of the data items which can be reported and their conditions.

### **Summary Data for Integrated Highway Inventory(IHI)**

**Highway Number:** A State marked and/or maintained highway.

**Begin and End Reference Post:** The starting and ending reference post of the section. The reference posts are not the logmile linear referencing system.

**Length:** The length of the section in miles.

**District:** Corresponding engineering district.

**County:** The Nebraska county where the highway section is located.

**Surface Percentage:** This will be the percentage of each surface type ascending and descending in this section of highway. There maybe more than one surface type for some sections of pavement. Some sections may consist of more than one project. The surface type are Bit: Bituminous, Composite: Asphaltic Concrete over Portland Cement Concrete, PCC: Portland Cement Concrete, and Other: Brick, gravel or earth.

**Age:** This is the year since last major reconstruction or resurfacing. There may be more than one age value reported as some sections consist of more than one project.

**ADT:** Average Daily two-way traffic count.

**Truck ADT:** The average daily commercial truck count, two-way.

**D18K:** The commercial truck count is converted to equivalent 18-kip axle loads (a kip is 1000 lbs.)

**Shoulders:** This data provides information if the section has surfaced shoulders or if it is on the surfaced shoulder system.

**Shoulder Percentages:** This will be the percentage of paved or unpaved shoulders for a section of pavement and the condition rating for the surfaced segments. The rating will be a 0-10 number with 10 being the best.

**Lane Num:** This will be a number 01, 02, 03, etc. denoting the number of lanes in each direction for a segment of highway. Numbering begins at the centerline or median and proceeds toward the shoulder of the road.

**Lane Direction Code:** This will be a letter A, B, or D Identification. B = Both directions usually on a two lane road, A and D = ascending and descending usually on a multilane road.

**Section Location:** A general description of the section's location in Nebraska.

**State Functional Class:** This value is in numerical code. 1=Interstate, 2=Expressway, 3=Major Arterial-Principal, 4=Major Arterial-Intermediate, 5=Major Arterial-Non-continuous, 6=Major Arterial-Scenic Recreation, 7=Other Arterials, 8=Collectors, 9=Local, 10 =Minimum Maintenance, and 99=Under Construction.

National Functional Class: This value is in numerical code. 1=Rural-Principal Arterial-Interstate, 2=Rural-Principal Arterial-Other, 6=Rural-Minor Arterial, 7=Rural-Major Collector, 8=Rural-Minor Collector, 9=Rural-Local, Values 10 or above are City Functional Classes and 99 = Under Construction.

Roughness, IRI: The roughness or IRI, the International Roughness Index, is measured in mm/m.

Cracking Index: This is a rating value used to quantify the amount of cracking based on the severity and extent noted during the visual inspection.

Transverse Cracking: The transverse/thermal cracking index is expressed as an index on a scale of 0 to 100 with 0 being the best condition and 100 the worst. The index reflects the severity and extent of transverse cracking on a bituminous pavement.

Rutting: The average rut depth of both wheel paths measured with Nebraska's profiler in mm. Rutting is measured only on bituminous pavements.

% Over 13 mm: The percentage of rutting on a bituminous pavement segment over 13 mm deep. This is an indicator that an improvement is needed. Rutting over 13% is considered to be poor.

Friction Number: The friction number last measured on the pavement. It requires 3 years to completely inventory Nebraska's highway system for friction measurement. As the data may be at least 3 years old, the interpretation of this information will require contact with the Materials and Research Division.

PSI: The Present Serviceability Index or PSI. This is a numerical value indicating the ride quality of the pavements. PSI is a function of roughness IRI, cracking, and rutting. It is on a scale of 0 to 5 with 0 being the worst condition and 5 the best.

Current NSI: The Nebraska Serviceability Index. A value on a scale of 0 to 100 with 0 the worst and 100 the best condition. It represents the condition of the pavement at the time of measurement. This value is used for development of remaining life values. See Appendix B.

Historical Low NSI: The lowest NSI which has been recorded for the pavement since the last major resurfacing or reconstruction. This value will be lower or equal to the current NSI. Review of this value with current NSI will provide a better overview of the real status of the pavement condition.

% Joint Seal: A PCC factor denoting if the nominal joint seal at a sample site has any failures.

% Bad Joints: The joint distress is a PCC term indicating the percentage of joints observed to be spalled for a sample segment.

% Repairs: This is a PCC term that indicates the total percentage of joints and slabs that have been repaired at the sample site.

% Bad Panels: The percentage of the slabs on PCC observed to be cracked. The percentage amount includes slabs with Class I and Class II (low and high severity) cracks. Displacement of the slab panels may be insignificant or in a poor condition.

Faulting: The average faulting at the joints and transverse cracks in mm.

Optimum Rehab Year: The best year for resurfacing a pavement based on the historical and current pavement condition. It is the year when the benefit to cost ratio of resurfacing a pavement is at a maximum.

Critical Rehab Year: The year at which most of the traveling public and engineers would find the pavement in poor condition. Pavement distress is of such magnitude that complete reconstruction is often needed.

Cracking and Patching

Surface Cracking

Cracking Index less than 15..... Good  
15 to 30 ..... Fair  
Over 30 ..... Poor

Transverse Cracking

Thermal Cracking Index less than 30..... Good  
30 to 60 ..... Fair  
Over 60 ..... Poor

Rutting

Ave. Rut Depths less than or equal to 3 mm Very Good  
>3 mm and <6 mm ..... Good  
>=6 mm and <8 mm ..... Fair  
>=8 mm ..... Poor

PSI

4.0 thru 5.0 ..... Very Good  
3.0 to 4.0 ..... Good  
2.0 to 3.0 ..... Fair  
1.0 to 2.0 ..... Poor  
0.0 to 1.0 ..... Very Poor

NSI

90 thru 100 ..... Very Good  
70 to 90 ..... Good  
50 to 70 ..... Fair  
30 to 50 ..... Poor  
0 to 30 ..... Very Poor

Joint Seal

No failures present ..... Good  
Any failures Observed ..... Needs sealant

Joint Distress

No spalling ..... Good  
Spalling but less than 30% ..... Fair  
Over 30% spalling ..... Poor

Slab Cracking

No cracking ..... Good

<u>Cracking</u>	<u>% Panels Cracked</u>	<u>Displacement</u>	
	1 to 100%	Low Sev	Tolerable
	1 to 50%	Moderate Sev	Tolerable
	1 to 25%	High Sev	Tolerable
	Over 50%	Moderate Sev	Poor
	Over 25%	High Sev	Poor

Faulting

No faulting ..... Good

Faulting less than 6 mm ..... Fair

Faulting 6 mm or greater ..... Poor

IRI All Pavements

Less than 0.85 mm/m..... Very Good

0.86 to 2.48 mm/m ..... Good

2.49 to 3.33 mm/m ..... Fair

3.34 to 4.21 mm/m ..... Poor

4.22 or greater..... Very Poor

Maintenance Costs 5 Year Average(In/mile)

Under \$250 ..... Good

\$250 to \$700 ..... Fair

\$700 or more ..... Poor

## How to Access Pavement Management Data:

Shown below is a step-by-step procedure you may use to obtain current and historical data for highways in your area.

1. Open a Mainframe Session
2. Type C1, press enter.
3. A "Production CICS1 Region" screen will appear, press enter.
4. Type in your User ID: (if your number is DOR 26002 use DR26002).
5. Type in your Password, press enter.
6. Next screen choose selection "8" (IHI) IHI Integrated Highway Inventory System, press enter.
7. On the Main Menu screen choose "18" Roadway Condition, press enter.
8. On the Roadway Condition Menu choose "02" Query, press enter.
9. On the Roadway Condition Query Menu choose what data you want to review. For example: choose "03" Bituminous Condition Ratings, press enter.
10. Enter Highway Number: Example "002"
  - a. Enter Beg Ref Post, if desired.
  - b. Enter End Ref Post, if desired.
  - c. Enter Lane Dir Cde, if desired.
  - d. Enter Lane Typ Cde, if desired.
  - e. Enter Lane Num, if desired.
  - f. Enter Start/End Dates, if you want to see more than the current data.
  - g. Enter Restrtn Idx Low/Hi, select range of Restoration Index values, if desired.
  - h. Enter Crking Idx Low/Hi, select range of Cracking Index values, if desired.
11. Press enter. Below is a sample of this ratings screen.

```

RDCX302                               Integrated Highway Inventory           07/15/05
                                       Bituminous Condition Rating       10:20:57
                                       Query
    Hwy Num: 002
    Beg Ref Post: 095.660
    End Ref Post: 101.410
    Lane Dir Cde: B
    Lane Typ Cde: TH
    Lane Num: 01
    Start/End Dates:
    Restrtn Idx Low/Hi:
    Crking Idx Low/Hi:
  
```

Hwy Num	Ref Post	Ln Dr Cd	Ln Tp Ln	Test Date	Edg Crk S E	Whl Pth S E	CLJ S E	BWP S E	RBC S E	Trn Crk S E	Ali S E	l S E	Pat S E	W S E	R S E	Bit A S E	Rmk Cde
002	95.660	B TH	1 03-14-2005	86.19	RUT =	L T	L E	L T	L T	M C							85.90
002	96.000	B TH	1 03-14-2005	86.17	L T	L T	L E	L T	L T	M C							86.00
002	97.000	B TH	1 03-14-2005	86.00	L T	M T	L O	L T	L T	M C							85.80
002	98.000	B TH	1 03-14-2005	85.95	L T	L T	L E	L T	L T	M C	L T						85.80
002	99.000	B TH	1 03-14-2005	86.17	L T	L T	L E	L T	L T	M C							86.00
002	100.000	B TH	1 03-14-2005	72.18	L T	L T	L E		L T	H C							72.00
002	101.000	B TH	1 03-14-2005	86.17	L T	L T	L E	L T	L T	M C							85.80
002	101.410	B TH	1 03-14-2005	93.76	L T	L T	L E	L T	L T	L C	L T						93.20

```

Command ==>
QUERY FUNCTION COMPLETE
PF1 =Help      PF2 =      PF3 =Exit    PF4 =      PF5 =Refresh PF6 =PrntScrn
PF7 =Bkwd     PF8 =Fwd   PF9 =      PF10=      PF11=      PF12=PrevScrn
PF13=        PF14=      PF15=      PF16=      PF17=      PF18=
PF19=TopRgn  PF20=BotRgn PF21=      PF22=      PF23=      PF24=
  
```

12. Follow the directions on the lower portion of the screen in reference to the "PF" keys ("F" keys on the keyboard, the upper row of keys). The "PF" keys 13 and above can be accessed by pressing the "Shift" + "F" key. Example "PF19" = Shift + F7; "PF20" = Shift + F8; etc.

If at step #9 above, you chose to look at "01" Roadway Condition Summary Query; Pavement Management Data can also be accessed there. However, it will only be for the section being summarized. If you select a section with both PCC and bituminous ratings, then you will see the percentages and separate data on the summary screen. The process would then be Steps 1 thru 8 as above, then:

9. Choose "01" Roadway Condition Summary Query, press enter.
10. Enter District number on this screen, press enter.
11. Scroll down list (F8) and choose a section and place an "X" in the "Sel" column on the line of your selection, press enter.
12. Press enter on the next screen.
13. The next screen is the "Nebraska Pavement Management System Summary Query" screen. If you place the cursor in front of the IRI data on the lower portion of the screen or Rutting data, if this is a bituminous section or Faulting if this is a PCC section and press "F4", the profiler data for this section will be displayed. If the cursor is placed in front of the Cracking Index, Trans. Cracking, NSI or Hist Low NSI, if bituminous and press "F4", the bituminous ratings for this section will be displayed. Likewise, if the cursor is placed in front of the PCC rating elements and "F4" is pressed, the PCC ratings for this section will be displayed.
14. There are other types of data that are also accessible from this screen. "F7" calls up all the Crew Card Transactions for this section. "F9" shows the Maintenance Costs and various activities for the last 5 years. "F10" shows the condition history and the ratings for this section for the last 10 years.



## **APPENDIX B**

### **METHODS FOR DERIVATION OF PAVEMENT CONDITION RATINGS**

## Introduction

A pavement condition index provides a measure of the severity and extent of pavement surface distress. It provided a measure of the relative urgency for pavement rehabilitation. In 1985, a method for deriving a pavement restoration index was developed. The initial method was a modification of the system reported by the Washington DOT. The initial index was a composite index. It was recognized at a very early period that a pavement could be in poor condition with respect to a specific distress but still in acceptable condition as indicated by the composite index. For this reason, a different approach was implemented. Distress forms of a similar nature were categorized by utility condition index. The poorest utility index provided the base for calculation of the restoration index. The base index was depreciated on the basis of the severity and extent of the distresses from the other categories. This concept was carried over to the calculation of the remaining service life. The poorest remaining service life was taken as the remaining service life of the pavement.

This appendix describes in detail the methods used by the Department for derivation of the restoration index of bituminous pavements. The development of the methods required extensive statistical analysis of distress measured during 1985. The SAS software system resident on the Department's IBM 370 computer using the CMS environment was used for the analysis.

To start, multivariate factor analysis was used to define and confirm the groups of similar pavement distress. By way of example, there were 4 similar categories of distress for bituminous pavements. Next, weighting values were assigned to levels of severity defined for the pavement distress (i.e. low, moderate, and high). Using a linear model, each distress factor was defined by a sum of the extent of each distress multiplied by its severity.

For each distress factor, the maximum value at which the condition of the pavement section would be considered poor was defined. This score was assigned a value of 50. A modified exponential equation was then used to provide a numerical scale of 0 to 100 with 0 as the worst pavement and 100 the best. The lowest score was taken as the base restoration index. The value was further depreciated on the basis of the magnitude of severity and extent of the other distress factors as well as measured faulting or rutting of the pavement. The final value was termed the Nebraska Serviceability Index or NSI.

The first cut NSI values were reviewed (1985) and adjustments to the distress equations made on the basis of these analysis. This consisted of redefining the maximum extent of each distress category that was acceptable by the Department.

Frequency polygons were plotted of all the NSI data for each pavement type. The coefficients of the modified exponential equations were adjusted to provide a flatter distribution of data similar to frequency distribution plots of projects with pavement age. The final equations have provided the NSI for Nebraska pavements with little modification since 1985. The slight modifications have been associated with changes in 1) numerical value of certain severity codes and 2) methods of measuring certain distress forms such as faulting in PCC.

**NSI for Bituminous Pavements**

The tabulation which follows lists 4 Distress Groups and associated distress included in each group.

<u>Factor</u>	<u>Pavement Distresses Included</u>
1.	Longitudinal Cracking including: Edge Cracking Centerline Cracking Wheel Path Cracking Between Wheel Path Cracking Alligator or Fatigue Cracking Failures and Potholes
2.	Transverse Cracking (Thermal and Reflective) Block Cracking
3.	Raveling and Weathering Excess asphalt or bleeding
4.	Pavement Rutting (as measured with Profiler)

The four distress factors were developed from multivariate factor analysis (4). A utility index is calculated for each factor. The index is based on a scale of 0 to 100 with 0 being the poorest and 100 the best. The methodology for establishing the indices for the distress factors is similar to that reported by Baladi (5). Exponential equations are used to derive the utility indices for the factors. A utility index is determined for factors 1, 2, and 4.

The lowest utility index derived from the distress factors is used as a base NSI value. Base NSI values are depreciated slightly on the basis of value of 1) the other two calculated indices and 2) the remaining distress factor 3. The NSI is then derived using the base restoration index and the rutting or faulting.

The algorithms and codes which follow define elements required for calculation of Nebraska's NSI for bituminous and composite (asphaltic concrete over PCC).

**Bituminous Pavement Severity and Extent Codes:**

**Severity Codes:**

For edge, centerline, wheel path, between wheel path, and alligator cracking; ravel/weathering, and excessive asphalt.

<u>Severity</u>	<u>Numerical Weight</u>
Blank .....	0.0
L .....	0.2
M .....	0.8
H.....	1.0

For grid-block cracking:

<u>Severity</u>	<u>Numerical Weight</u>
Blank .....	0.0
L .....	0.2
M .....	0.4
H.....	0.8
X.....	1.2

For transverse cracking:

<u>Severity</u>	<u>Numerical Weight</u>
Blank .....	0.0
L .....	0.2
M .....	0.4
H.....	0.8
X.....	1.2

For patching:

<u>Severity</u>	<u>Numerical Weight</u>
Blank .....	0.0
G .....	0.2
P.....	1.0

Extent codes:

For all distress types except ravel/weathering and excessive asphalt:

<u>Extent</u>	<u>Numerical Weight</u>
Blank .....	0.0
T.....	0.1
O .....	0.3
F.....	0.5
E.....	0.7
C.....	0.9

Determination of NSI.

sev = severity  
ext = extent

- a. eg = edge\_sev\*edge\_ext
- wp = wheel\_path\_sev\*wheel\_path\_ext
- CL = centerline\_sev\*centerline\_ext
- bw = between\_wheel\_path\_sev\*between\_wheel\_path\_ext
- al = alligator\_sev\*alligator\_ext
- fl = failures\_ext
- tc = transverse\_crack\_sev\*transverse\_crack\_ext
- bc = grid\_block\_crack\_sev\*grid\_block\_crack\_ext
- rv = ravel\_sev
- xs = excess\_sev
- pa = patching\_sev\*patching\_ext
- ru = average\_rutting\_in\_millimeters

b. To compute NSI for bituminous and composite pavements:

- E = 2.718281828
- R\_eg = 0.125
- R\_CL = 0.125
- R\_bw = 0.250
- R\_wp = 0.500
- R\_al = 1.000
- R\_fl = 1.000

Compute  $cl = (R_{eg} * eg) + (R_{CL} * CL) + (R_{bw} * bw) + (R_{wp} * wp)$

$c2 = (R_{al} * al)$

$c3 = (R_{fl} * fl)$

$c4 = 0.556$

$c5 = 0.714$

$c6 = 1.000$

$crack = (c1 * c4) + (c2 * c5) + (c3 * c6)$

$R_{bc} = 1.000$

$R_{tc} = 1.000$

$R_{rv} = 0.600$

$R_{xs} = 0.400$

$R_{pa} = 0.400$

$therm = (R_{bc} * bc) + (R_{tc} * tc)$

$cosmo = (R_{rv} * rv) + (R_{xs} * xs)$

$waves = R_{pa} * pa$

$coeff\_1 = 0.6931473$

$coeff\_2 = 0.5000000$

$coeff\_3 = 0.8870000$

$coeff\_4 = 1.4000000$

$coeff\_5 = 1.2000000$

$coeff\_6 = 0.6931473$

$Factor1 = E^{**} - [coeff\_1 * (crack / coeff\_2)^{**} coeff\_3]$

$Factor2 = E^{**} - [coeff\_6 * (therm / coeff\_4)^{**} coeff\_5]$

If  $Factor\ 2 < Factor\ 1$  then  $Factor\ 3 = Factor2$

Else  $Factor3 = Factor\ 1$

If  $Factor1 = Factor3$  then  $Factor4 = Factor3 * Factor2^{**} 0.10$

If  $Factor2 = Factor\ 3$  then  $Factor4 = Factor3 * Factor1^{**} 0.10$

$coeff\_7 = 0.1109000$

$coeff\_8 = 0.5108260$

$coeff\_9 = 15.875000$

$coeff\_10 = 2.0000000$

$Factor5 = E^{**} - [coeff\_7 * (cosmo + waves)]$

$Factor6 = Factor4 * Factor5$

$Factor7 = E^{**} - [coeff\_8 * (ru / coeff\_9)^{**} coeff\_10]$

If  $Factor\ 7 < Factor6$  then  $Factor8 = Factor7$

Else  $Factor8 = Factor6$

If  $Factor8 = Factor6$  then  $Factor8 = Factor8 * Factor7^{**} 0.10$

If  $Factor8 = Factor7$  then  $Factor8 = Factor8 * Factor6^{**} 0.10$

$coeff\_11 = 100.0000$

$NSI = Factor8 * coeff\_11$

**NSI for Portland Cement Concrete**

The terms and mathematical treatments which follow are used for the rating of rural non-interstate PCC pavement in Nebraska. A series of 10 joints and panels are rated at each sample site.

Joints

Joints Repaired Amount (JR):

<u>Valid Values</u>	<u>Special Instructions</u>
0 – 10 .....	None

<u>Severity</u>	<u>Numerical Weight</u>
Blank .....	0.0
L .....	0.5
M .....	0.8
H.....	1.3

Joints Spalled Amount (JCS):

<u>Valid Values</u>	<u>Special Instructions</u>
0 – 10 .....	None

Joint Seal Condition (SE):

<u>Severity</u>	<u>Numerical Weight</u>
Blank .....	0.0
X.....	1.0

Joint Fault Depth (FAULT)

<u>Valid Values</u>	<u>Special Instructions</u>
0 – 99 .....	In mm

Panels

Class I Crack Amount (CL\_I):

<u>Valid Values</u>	<u>Special Instructions</u>
0 – 10 .....	None

Class II Crack Amount (CL\_II):

<u>Valid Values</u>	<u>Special Instructions</u>
0 – 10 .....	None

Total amount of Class I and Class II cracking shall not exceed 10.

Pattern Cracks (PC):

<u>Severity</u>	<u>Numerical Weight</u>
Blank .....	0.0
L .....	0.5
M .....	0.8
H.....	1.3

Panels Spalled Amount (PS):

<u>Valid Values</u>	<u>Special Instructions</u>
0 – 10 .....	None

Panels Repaired Amount (PR):

<u>Valid Values</u>	<u>Special Instructions</u>
0 – 10 .....	None

Panel Crack Seal Condition (PCS):

<u>Severity</u>	<u>Numerical Weight</u>
Blank .....	0.0 Values are set to zero and not
X.....	0.0 used in derivation of NSI
G .....	0.0
P.....	0.0

Fault Depth of Slab Displacement (SD):

<u>Severity</u>	<u>Numerical Weight</u>
Blank .....	0.0034655
L .....	0.0051083
M .....	0.0069315
H.....	0.0091629

To compute the NSI for concrete pavement (PCR).

Constants: E = 2.718281828

coeff\_1 = 100

coeff\_2 = 0.035700

coeff\_3 = 0.162500

coeff\_4 = 0.088700

coeff\_5 = 0.035700

coeff\_6 = 0.015300

coeff\_7 = 0.005108

coeff\_8 = 0.105400

coeff\_9 = 0.035700

CL\_A = 5

CL\_B = 10

CL\_C = 10

Compute: S3 = [(CL\_A \* CL\_I) + (CL\_B \* CL\_II)] / CL\_C

A = coeff\_2 \* JR

B = coeff\_3 \* JRATE

C = coeff\_4 \* JCS

D = coeff\_5 \* PS

E1 = coeff\_6 \* SE

F = coeff\_7 \* FAULT \*\* 2

G = coeff\_8 \* PC

H = coeff\_9 \* PR

I = SD \* S3 \*\* 2

PCR = coeff\_1 \* E \*\* -(A+B+C+D+E1+F+G+H+I)

Rating data collected before 1994 was in a slightly different format than the ratings collected after 1994. A program has been used to factor the pre 1994 data to match the post 1994 data so we can perform historical analysis.

## **APPENDIX C**

### **METHODS FOR DERIVATION OF PAVEMENT**

#### **PRESENT SERVICEABILITY INDEX**

## Introduction

The equations which follow provide the method for calculating the present serviceability index (PSI) for bituminous and rigid pavements. The equations have been developed over time and represent several correlations which the Department has used to relate measure of roughness to the PSI. The models chosen represent modifications of statistically fit curves to roughness data. In 1989, the roughness data obtained from the Department's South Dakota Profiler was correlated to roughness as measured with the Mays Ride Meter. Power series equations were fit to the data and the resulting equations inserted into PSI equations developed by the Department.

Nebraska does not use roughness alone in derivation of PSI. Compensation is made for cracking and rutting of bituminous pavements, and faulting, joint distress, slab cracking and repair amount are observed for Portland cement concrete.

The PSI is determined from a set of equations as follows:

### For Bituminous Pavements:

$$\begin{aligned} \text{WPSI} &= (4.4 * E ** ((\text{FLEX1} * \text{SDPROF} ** 2.726) - (\text{FLEX3} * (\text{WGT\_RUT}/25.4) ** 2))) \\ \text{PSI} &= \text{PSI} * (E ** (-0.2 * \text{TCRACK})) \end{aligned}$$

where:

$$\begin{aligned} E &= 2.718281828 \\ \text{FLEX1} &= -0.017474 \\ \text{FLEX3} &= 0.74118 \\ \text{RUT} &= \text{WEIGHTED RUT DEPTH IN MM} \\ \text{SDPROF} &= \text{WEIGHTED IRI} \\ \text{IRI} &= \text{INTERNATIONAL ROUGHNESS INDEX, MM/M} \\ \text{TCRACK} &= \text{WEIGHTED TRANSVERSE CRACKING VALUE AVG(SEVTC*EXTTC)} \\ \text{SEVTC} &= \text{SEVERITY OF TRANSVERSE CRACKING} \\ \text{EXTTC} &= \text{EXTENT OF TRANSVERSE CRACKING} \end{aligned}$$

### For Asphaltic Concrete over Portland Cement Concrete:

$$\begin{aligned} \text{WPSI} &= (4.5 * E ** (\text{CMP1} * \text{SDPROF} ** 2.726) - (\text{CMP3} * ((\text{WGT\_RUT}/25.4) ** 2))) \\ \text{PSI} &= \text{WPSI} (E ** (-0.2 * \text{TCRACK})) \end{aligned}$$

where:

$$\begin{aligned} E &= 2.718281828 \\ \text{CMP1} &= -0.01747 \\ \text{CMP3} &= 0.74118 \\ \text{CRACK} &= \% \text{CRACKING} \\ \text{RUT} &= \text{WEIGHTED RUT DEPTH IN MM} \\ \text{SDPROF} &= \text{WEIGHTED IRI} \\ \text{IRI} &= \text{INTERNATIONAL ROUGHNESS INDEX, MM/M} \\ \text{TCRACK} &= \text{WEIGHTED TRANSVERSE CRACKING VALUE AVG(SEVTC*EXTTC)} \\ \text{SEVTC} &= \text{SEVERITY OF TRANSVERSE CRACKING} \\ \text{EXTTC} &= \text{EXTENT OF TRANSVERSE CRACKING} \end{aligned}$$

For Portland Cement Concrete:

$$\text{PSI} = 5.0 * E ** ((\text{RIG1} * \text{SDPROF} ** 1.71) + (\text{RIG2} * \text{JT\_DSTRESS\_AMT}) + (\text{RIG2} * \text{SLAB\_CRKNG}) + (\text{RIG3} * \text{REPAIR\_AMT}) + (\text{RIG4} * \text{FAULT\_AMT} ** 2))$$

where:

E	=	2.718281828
RIG1	=	-8.13700000E-02
RIG2	=	-2.500E-03
RIG3	=	-2.000E-04
RIG4	=	-1.2000E-3
FAULT AMT	=	AVERAGE FAULT DEPTH IN MM
SLAB_CRKNG	=	% OF CLASS I AND CLASS II CRACKS
REPAIR_AMT	=	% OF REPAIRED JOINTS
SDPROF	=	WEIGHTED IRI
IRI	=	INTERNATIONAL ROUGHNESS INDEX, MM/M
JT_DSTRESS_AMT	=	% SPALLED JOINTS

## **APPENDIX D**

### **PAVEMENT DISTRESS AND RELATED VALID MAINTENANCE STRATEGIES**

## Introduction

The following decision trees for bituminous and pcc pavements are from the Pavement Optimization Program (POP). The improvement strategies which would be applied to correct pavement distress deficiencies are also listed.

### Bituminous Pavements

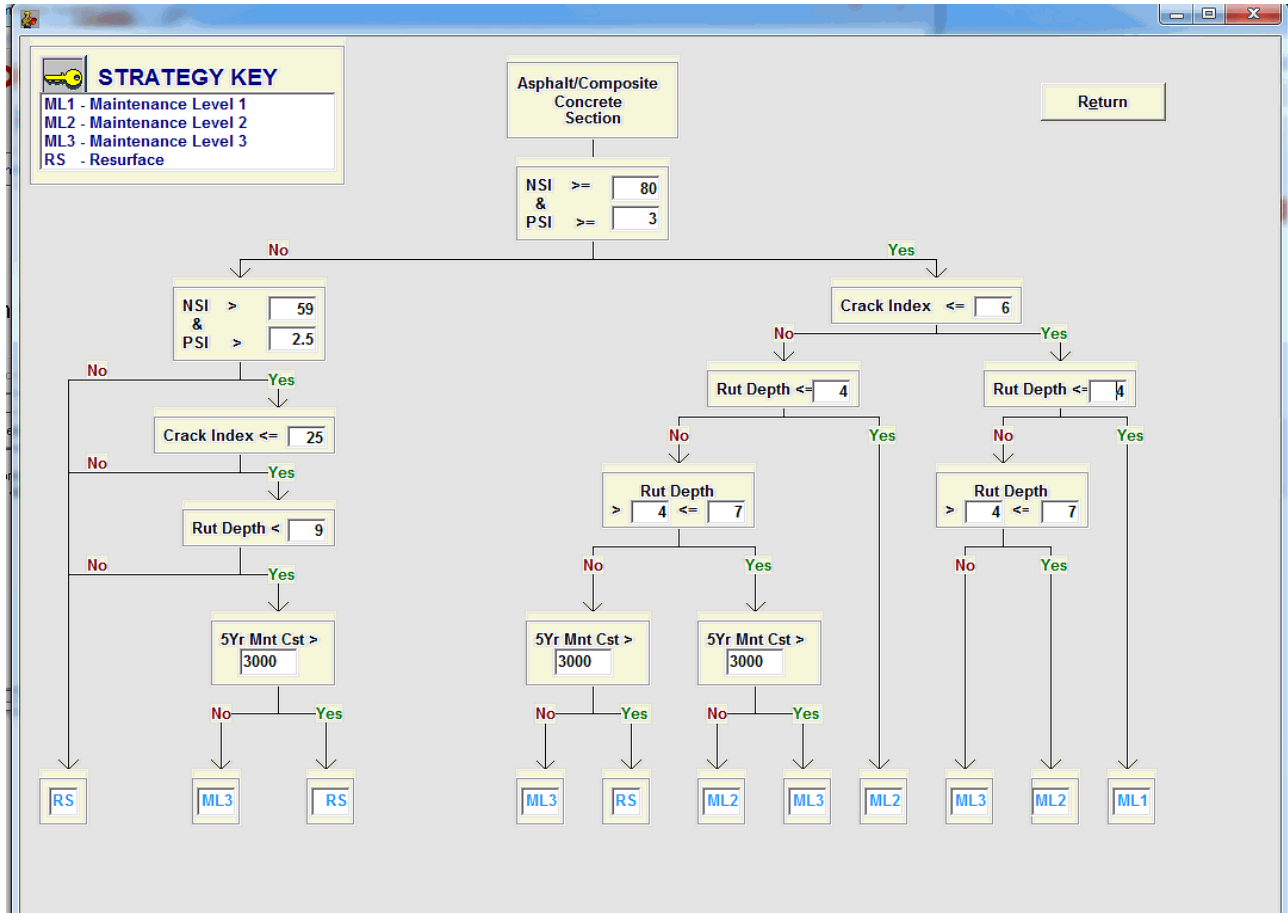

### AC DECISION CRITERIA:

A pavement section must have had at least 3 years since the last improvement before it goes into the decision tree. Also, if the section has a NSI  $>$  85 and the PSI  $>$  3.0 and the crack index  $<$  4 and the rut depth  $<$  4 mm then no action is required so it doesn't go through the decision tree.

Each qualifying section falls through this tree and lands on only one strategy. Actions can be ML1, ML2, ML3, AND RS as conditions worsen. The first thing it checks is the NSI and PSI. Then it checks the cracking, rutting, and 5-year maintenance costs to determine the most appropriate strategy.

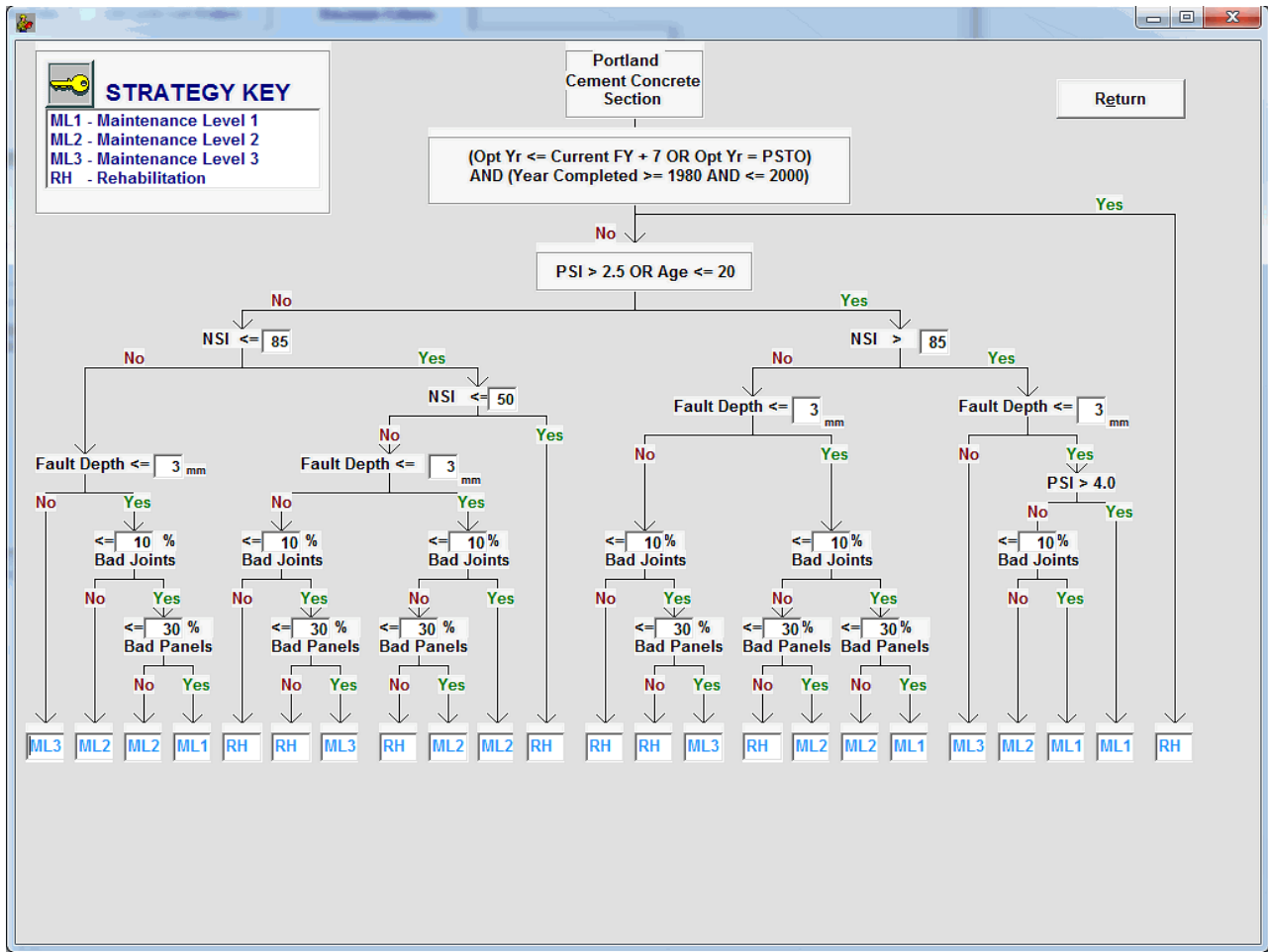

**PCC DECISION CRITERIA:**

A pavement section must have had at least 7 years since the last improvement before it goes into the decision tree. Also, if the section has faulting < 2.5mm and the bad joints < 10% and the bad panels < 30% and  $NSI \geq 85$  then no action is required so it doesn't go through the decision tree.

Each qualifying records data falls through this tree and falls on only one strategy. Actions can be ML1, ML2, ML3, and RH as conditions worsen. The first thing checked is the PSI and Age. Then it checks the NSI, Faulting, Bad Joints and Bad Panels to determine the most appropriate strategy.

A check to identify Alkali Silica Reaction (ASR) was added in 2008 to the beginning of the decision tree. If the concrete was built between 1980 and 2000, we expect to have ASR issues early on. These Sections now fall into the rehabilitation category for the suggested strategy and future ML1, ML2, and ML3 strategies are exempt to the 7 year wait period.

STRATEGIES:

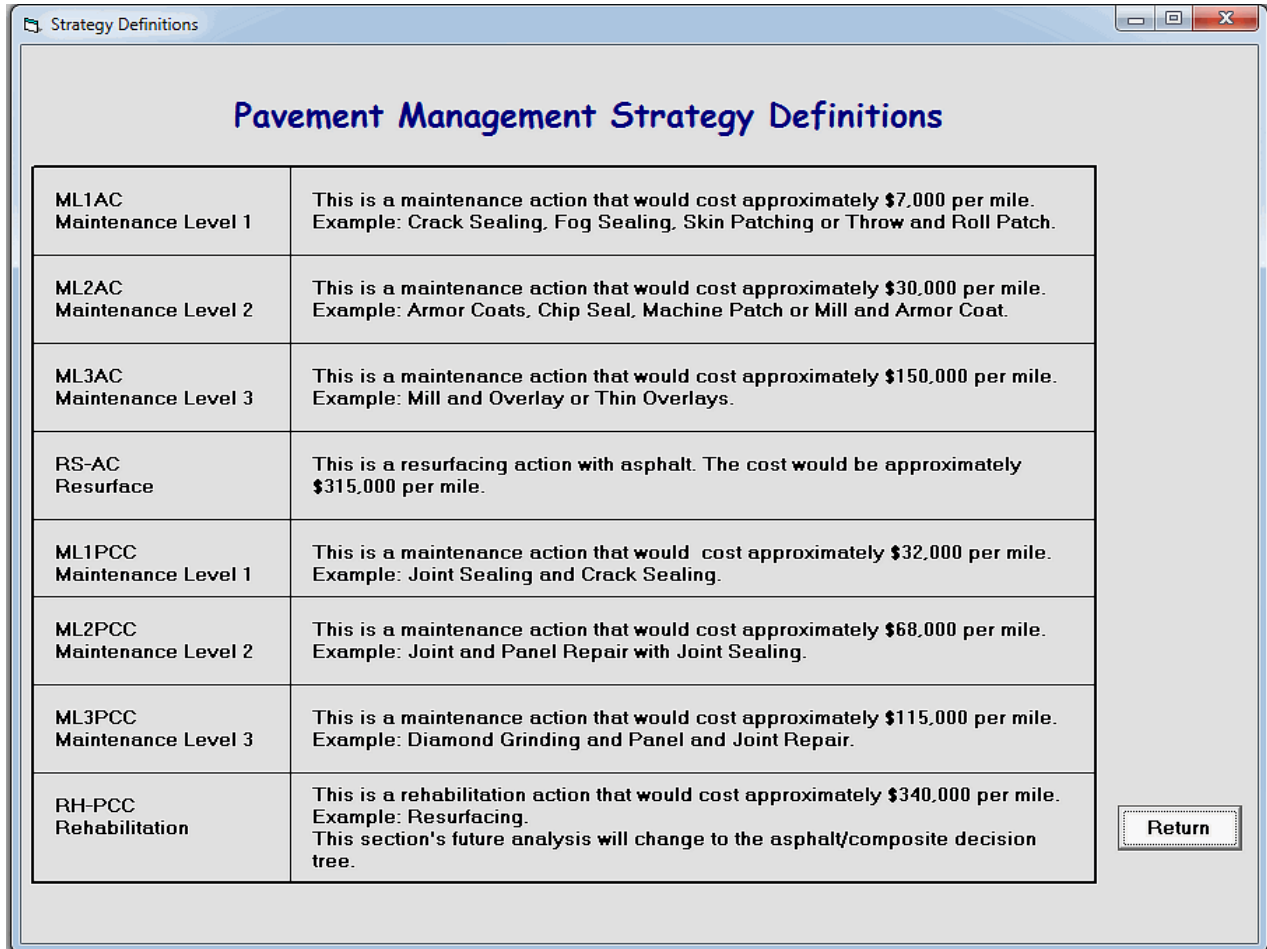

The screenshot shows a window titled "Strategy Definitions" with a table of pavement management strategies. The table has two columns: the first column lists the strategy name and level, and the second column provides a description and an example. A "Return" button is located at the bottom right of the window.

Strategy Name	Description and Example
ML1AC Maintenance Level 1	This is a maintenance action that would cost approximately \$7,000 per mile. Example: Crack Sealing, Fog Sealing, Skin Patching or Throw and Roll Patch.
ML2AC Maintenance Level 2	This is a maintenance action that would cost approximately \$30,000 per mile. Example: Armor Coats, Chip Seal, Machine Patch or Mill and Armor Coat.
ML3AC Maintenance Level 3	This is a maintenance action that would cost approximately \$150,000 per mile. Example: Mill and Overlay or Thin Overlays.
RS-AC Resurface	This is a resurfacing action with asphalt. The cost would be approximately \$315,000 per mile.
ML1PCC Maintenance Level 1	This is a maintenance action that would cost approximately \$32,000 per mile. Example: Joint Sealing and Crack Sealing.
ML2PCC Maintenance Level 2	This is a maintenance action that would cost approximately \$68,000 per mile. Example: Joint and Panel Repair with Joint Sealing.
ML3PCC Maintenance Level 3	This is a maintenance action that would cost approximately \$115,000 per mile. Example: Diamond Grinding and Panel and Joint Repair.
RH-PCC Rehabilitation	This is a rehabilitation action that would cost approximately \$340,000 per mile. Example: Resurfacing. This section's future analysis will change to the asphalt/composite decision tree.

These are the predicted strategies that come from the decision trees and related costs. All costs shown include overhead costs of 35% for Engineering and Contingencies.

## **APPENDIX E**

### **REMAINING SERVICE LIFE EQUATIONS**

## Introduction

As a pavement ages, the ability of the currently measured NSI to reflect the true quality of the pavement diminishes. An NSI of 85 for a 8 year old pavement has different meaning than a NSI of 85 for a 25 year old pavement. The latter pavement may have undergone many minor maintenance repairs over its service life, while the former may have had none at all.

In order to enhance our present system to provide more meaningful information, the following techniques used for analysis and reporting data have been implemented into the Pavement Management System. The first is reporting the current and historic low NSI which have been measured. The second technique involves the use of remaining service life equations.

### Reporting of Pavement Condition

The reporting of the current and historically low NSI provides 1) a rapid method for evaluating impacts of maintenance on the pavement and 2) a better measure of the overall quality of the road. Using the scenario previously mentioned, the 8 year old pavement may likely have a current NSI of 85 and a historic low NSI of the same value. The 25 year old pavement could possibly have a historic low NSI value of 48. Review of both the current and historic values provides a better way of evaluating the quality of the pavement.

### Remaining Service Life

Several approaches exist for deriving remaining service life of a pavement. Regression and Markov analysis are commonly used methods. Regression analysis can be misleading due to reactive maintenance practices. The Markov methods are more complex and require accurate pavement condition measure which can be expensive and time consuming to collect.

Nebraska's approach for deriving remaining service life (RSL) has been to project the time it will take in years for the pavement to deteriorate to a given threshold condition from its current condition state. The method is based on assumptions that 1) the current condition state reflects the true quality of the pavement and 2) the deterioration for the pavement is generally consistent over time. Neither assumption is wholly true, but for pavement management work accomplished to date, the method has provided reasonable forecast of RSL.

Threshold values for NSI are 60 for rural bituminous and composite pavements and 50 for rural PCC. A PSI threshold of 2.5 is used for bituminous and PCC. Threshold values for Interstate pavement are NSI of 70 for bituminous or composite and 60 for PCC. The threshold PSI for Interstate pavement is 3.0.

## Methods of Calculation

To calculate total remaining service life:

- a. Round Current\_NSI to nearest whole number.
- b. Estimate of remaining service life (RSL) is derived from the following equation:

$$\text{RSL} = (\text{Current\_NSI} - \text{Threshold\_NSI}) / \text{Slope}$$

where Slope is equal to typical slope values for specific pavement types and designs.

Slope values used are as follows:

For non-interstate pavements

Bituminous and Composite pavement

If NSI  $\geq$  70 and age  $\geq$  12 and  
20 year TADT  $\geq$  200 then      Slope = 5.00, ELSE = 3.00

If NSI < 70 then                      Slope = 2.50

PCC pavement                              Slope = 1.4286

For interstate pavements

Bituminous or

Composite pavement                  Slope = 2.73

PCC pavement                              Slope = 2.000

The slope values are reviewed systematically to determine any major changes to the slopes. Changes made to the slope variables will effect the accuracy of historical reviews of data collected since 1985. (See Figure 2 for flowcharts on remaining life for bituminous and PCC pavements.)

## **APPENDIX F**

### **FAULTING FORMULA**

## **Faulting**

Faulting is calculated using the profiles from the vehicle wheel paths. Since faulting is worse near the shoulder of the roadway, the right wheel path is normally used to calculate the Fault Index.

Fault values are calculated by taking the delta changes between profile points. Every other profile point is used. Therefore, for the following profile points, P1, P2, P3, P4, P5, P6, P7, P8, P9, Pn-1, Pn, the fault values are (P3-P1), (P4-P2), (P5-P3), (P6-P4), (P7-P5), etc. If the fault value does not exceed the minimum tolerance, as specified by the user, the fault value is set to zero(0). The minimum tolerance for NDOR is 0.1 inch.

The fault values are then fed through an optimization routine that selects the peak fault value. Presently, this routine utilizes seven (7) successive fault values. The absolute value of the center fault value is compared against the absolute values of the other six. If the center fault is greater than the others, the value is kept. Otherwise, the fault value is set to zero(0). The selected values are used to calculate the Fault Index.

To get the fault index, an interval report must be selected. A Fault Index number is generated for each interval. Usually, the interval is set to 0.1 mile. The fault numbers (absolute values) are summed over the interval and divided by the number of faults to get the Fault Index. For NDOR, if the reported fault count for the interval is less than 32, the sum is divided by 32. Refer to the Profile Data loading instructions for details on loading the faulting data.

## **APPENDIX G**

### **RUTTING FORMULA**

# APPENDIX G

## RUTTING FORMULA

### THREE POINT BUMPER LASER SYSTEM

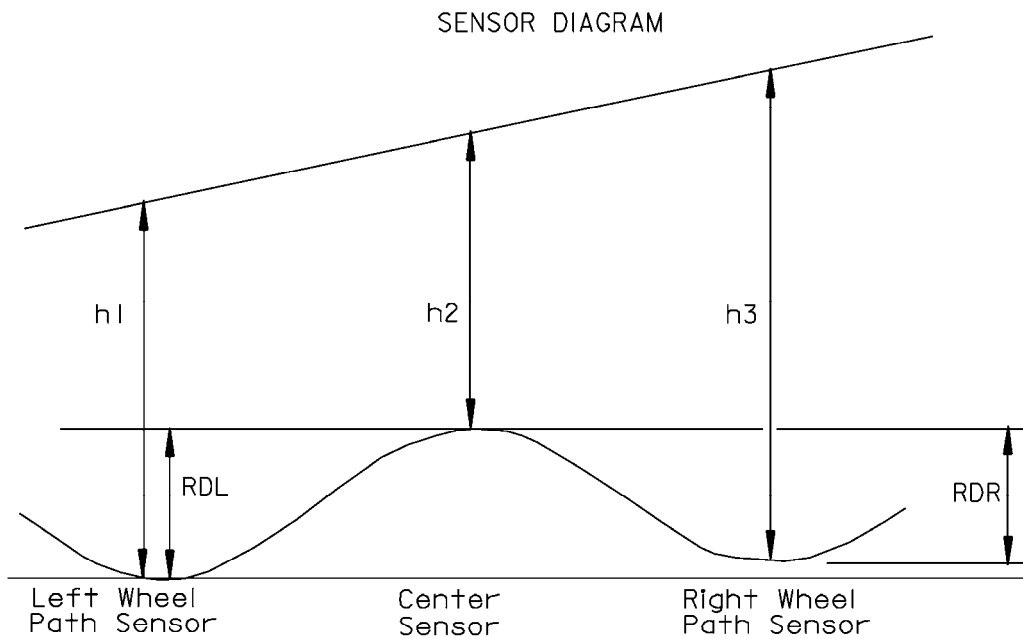

## INO TRANSVERSE PROFILING SYSTEM

IF THE DIFFERENCE BETWEEN THE LWP  
AND RWP IS MORE THAN 6 MM. THEN USE  
THE LOWER OF THE LWP OR RWP. IF THE  
INO DATA IS OUT OF RANGE THEN USE THE  
THREE POINT BUMPER LASER SYSTEM  
AVERAGE RUTTING.

## **APPENDIX H**

### **BUSINESS RULES FOR THE PAVEMENT MANAGEMENT DATABASE**

The Pavement Management System has several DB2 tables that are used to store data. The following is a list of the most pertinent data tables.

DORADM.HSNP0101-This table is used to define the pavement sections (P). Data is stored by section type, highway number, beginning and ending reference post and lane direction. The lane direction here refers to "A"(ascending) or "D"(descending) on a four lane highway or it is coded "B"(both) on a two lane highway. To look at the most recent data, you need to query the Deactivation Date(DCTVTN\_DT) = '9999-12-31'. The Activation Date (ACTVTN\_DT) is the actual date of the input. The Pavement Management Section maintains the pavement sections. The adjustments to the sections are made when we receive the Notice to Proceed notifications.

DORADM.HSNP0102-This table is maintained by the Classification and Needs Section that contains inventory information. Data is stored by highway number, beginning and ending reference post and lane direction. The section breaks are the needs sections. Upon notification of Notice to Proceed we set the Under Construction Flag to "Y" for the entire section being under construction or a "P" if the section has only part of it under construction. And then when the completion notification comes in we set the Under Construction Flag to "N". The Design Exception Switch is coded "Y" if a letter of design exceptions has been received.(This removes it from the Needs Assessment) or it is coded "N" for a design exception letter that did not remove it from the Needs Assessment. We also update some additional items that describe the project. To look at the most recent data, you need to query the Deactivation Date (DCTVTN\_DT) = '9999-12-31'. The Activation Date(ACTVTN\_DT) is the actual date of the input.

DORADM.LNEP0101 table has surface and base types, LNEP0102 has the surface and base depths, LNEP0103 has the lane widths, LNEP0104 has completion dates, LNEP0105 has the Project and Control numbers, LNEP0107 has the Milling data, and LNEP0109 has the special surface treatment data. LNEP0108 is a combined section data table of LNEP0101 thru LNEP0105 tables that stores data for highway sections defined by beginning and ending reference posts, lane direction and lane number. This table is maintained by the Data Collection unit that contains the current surface data information. This file is updated when we receive a copy of the "Notice to Proceed" on the project. We do make exceptions for realignments/relocations. If we are constructing adjacent to the original route, then we keep that existing route as the active record until we are notified that traffic has been moved to the new alignment. At that time we use the information for the new route.

DORADM.RDCP0101-This is the Profilometer data averaged and collected at 0.1 mile intervals. Data is stored by highway number, reference post, lane direction and lane number. The lane direction refers to the direction driven during the data collection and photo capturing. Ascending or descending lanes codes are used for both two and four lane highways. This was different than the rest of the DB2 tables lane direction definitions. So in 2006, with the implementation of the Pathway profiling system, a change was made in the way the data was stored to be more consistent with the other DB2 tables. Now the lane direction here refers to "A"(ascending) or "D"(descending) on a four lane highway or it is coded "B"(both) on a two lane highway. Items collected are right and left wheel path IRI, right and left wheel path rutting, average rutting, standard deviation of the rutting and the fault depth. To look at the most recent data, you need to query the Deactivation Date(DCTVTN\_DT) = '9999-12-31'. The Activation Date(ACTVTN\_DT) is the actual date of the profiling. Refer to the instructions for collecting and loading profiling data for detailed processes.

DORADM.RDCP0102-Bituminous condition rating data collected at every mile marker and Project section breaks. Data is stored by highway number, reference post, lane direction and lane number. The lane direction here refers to "A" (ascending) or "D"(descending) on a four

lane highway or it is coded "B"(both) on a two lane highway. Condition assessments are made for 11 bituminous visual distresses. In addition, cracking index, average rutting, restoration index and the bituminous remark code are calculated and included in the table. The restoration index is the condition based primarily on the most severe visual distress for that pavement section. A large increase or decrease is verified as part of our Quality Assurance (QA). The NSI rating uses the restoration index and the rutting. To look at the most recent data, you need to query the Deactivation Date (DCTVTN\_DT) = '9999-12-31'. The Activation Date (ACTVTN\_DT) is the actual date of the rating. See the instructions for collecting and loading bituminous data for the detailed processes.

DORADM.RDCP0103-PCC Condition rating data that is collected at every mile marker and Project section breaks. Data is stored by highway number, reference post, lane direction and lane number. The lane direction here refers to "A"(ascending) or "D"(descending) on a four lane highway or it is coded "B"(both) on a two lane highway. Condition assessments are made for 11 PCC visual distresses. The faulting is also included in the table. The restoration index is the condition based primarily on the most severe visual distress for that pavement section. A large increase or decrease is verified as part of our Quality Assurance (QA). The NSI rating uses the restoration index and the faulting. To look at the most recent data, you need to query the Deactivation Date(DCTVTN\_DT) = '9999-12-31'. The Activation Date (ACTVTN\_DT) is the actual date of the rating. See the instructions for collecting and loading PCC data for the detailed processes.

DORADM.RDCP0105-Paved shoulder condition rating data that is collected at every mile marker and Project section breaks where paved shoulders exist. Data is stored by highway number, reference post, lane direction and lane number. The lane direction here refers to "A"(ascending) or "D"(descending) on a four lane highway or it is coded "B"(both) on a two lane highway. Items collected are the lane to shoulder separation and the condition of the shoulder. To look at the most recent data, you need to query the Deactivation Date (DCTVTN\_DT) = '9999-12-31'. The Activation Date (ACTVTN\_DT) is the actual date of the rating.

DORADM.RDCP0106-Unpaved shoulder condition rating data that is collected at every mile marker and Project section breaks where unpaved shoulders exist. Data is stored by highway number, reference post, lane direction and lane number. The lane direction here refers to "A"(ascending) or "D"(descending) on a four lane highway or it is coded "B"(both) on a two lane highway. Items collected are the drop off, erosion and drainage. To look at the most recent data, you need to query the Deactivation Date (DCTVTN\_DT) = '9999-12-31'. The Activation Date(ACTVTN\_DT) is the actual date of the rating. In 2006 we discontinued the rating of unpaved shoulders.

DORADM.RDCP0107- Friction test results data that is stored by mile marker locations. Data is stored by highway number, reference post, lane direction and lane number. . The lane direction here refers to "A"(ascending) or "D"(descending) on a four lane highway or it is coded "B"(both) on a two lane highway. Items collected are the friction factor and the temperature at the time of the testing. To look at the most recent data, you need to query the Deactivation Date(DCTVTN\_DT) = '9999-12-31'. The Activation Date(ACTVTN\_DT) is the actual date of the testing.

DORADM.RDCP0501-This is the Crew Card Maintenance transaction table that has activity codes and hours. Data is stored by highway and then beginning and ending reference post. This data is then summarized to create the RDCP0500 table.

DORADM.RDCP0500-This is the District forces Maintenance Cost data that has summarized the RDCP0501 table for the last 5 years. Data is stored by Highway and mile marker.

DORADM.RDCP0108-This is combined section data table that stores data for highway sections defined by beginning and ending reference posts and lane direction. The lane direction here refers to "A"(ascending) or "D"(descending) on a four lane highway or it is coded "B"(both) on a two lane highway. Only one lane number can be used so on a two lane highway, lane one information is loaded. On a four lane highway, including the interstate, we load the lane two (outside) lane information. If you need to look at lane no. 1 data on a four lane highway, then you will have to look at the original data tables and join them to the Lane dependant information tables. (DORADM.LNEP\_\_\_\_). Only the most current data is loaded into RDCP0108 by moving in DCTVTN\_DT = '9999-12-31' records only. The table is loaded with both "Pavement Management Sections" and "Needs Assessment Sections". These sections limits are defined in the DORADM.HSNP0101 table. You need to specify this in the SECT\_TYP\_CDE for data analysis. This selection was added in August, 2004. RDCP0108 tables created before that were loaded with either Pavement Management Sections or Needs Assessment Sections. A list of dates for each section type is available. Smaller sections (less that 0.30 miles), that have little or no bearing on the decision making of larger adjacent sections, have been combined in the Pavement sections. And sections that have the same material types in similar years were combined to create project sized sections of 2 miles or more. If we do have a section that is less than a mile long and falls between the mile marker ratings, then we go back to next lowest mile marker rating and use it. If we have two material types in one section, then we calculate the condition based on the predominant material type. We use this predominance rule for most of the items. The deficiency flags and programming information are an exception to this. If any part of a section is flagged with a deficiency or is programmed, then the entire section is noted as such. We update the Pavement section and Needs section limits when we receive a Notice to Proceed and finalize them from the As-builts. Refer to the Rules for Combining Sections for complete details of the process. Ratings from the profilometer, bituminous, pcc, paved shoulder, and friction tables are combined in this RDCP0108 table. Additional data that is included and tied to these sections are the Inventory data, Programming data, Maintenance Activity data, Accident data, Pavement Management data and Needs Assessment data. This RDCP0108 table is a duplicate of the TAB file that is used for our SAS programs in the Needs Assessment and POP program. The program information that is moved into this table is limited to surface related actions. Line Improvement code < 7). In 2007, we started using the average of the left and right wheel path IRI's. Previously, we had used the right wheel path IRI. The rutting is an average of the left and right wheel path from the INO data. There is an exception, if the difference between the INO LWP and RWP is greater than 6 mm. then use the Lower of the LWP and RWP. The faulting uses the right wheel path values. The column called NSI\_TEST\_DT refers to the date of the visual condition rating. The IRI\_TEST\_DT refers to the date of profiling and photo capturing.